

# AN11276

## NTAG Antenna Design Guide

Rev. 1.5 — 27 April 2016  
242115

Application note  
COMPANY PUBLIC

### Document information

Info	Content
<b>Keywords</b>	NTAG, NTAG I <sup>2</sup> C, NTAG I <sup>2</sup> C <i>plus</i> , RFID Tag, Antenna Theory, Antenna Design, Measurement Methods, Antenna Design Procedure
<b>Abstract</b>	NTAG ICs need to be connected to an antenna to turn them into an operational RFID tag. This application note provides guidance for designing such antenna.



**Revision history**

Rev	Date	Description
1.5	20160427	Security status changed into COMPANY PUBLIC
1.4	20160201	NTAG I <sup>2</sup> C and NTAG I <sup>2</sup> C <i>plus</i> added
1.3	20130408	NTAG210 and NTAG212 added
1.1	20121106	Small text correction
1.0	20121012	First release

**Contact information**

For more information, please visit: <http://www.nxp.com>

For sales office addresses, please send an email to: [salesaddresses@nxp.com](mailto:salesaddresses@nxp.com)

## 1. Introduction

NXP Semiconductors' NTAG ICs provide a platform for the design of NFC Forum Type 2 Tag compliant tags and are designed to be used with NFC Forum's ISO/IEC 14443A enabled devices.

The RF interface complies with part 2 and 3 of the ISO/IEC 14443A standard [4] and [6].

Communication with the NTAG IC can only be established when the IC is connected to an antenna. This document provides all necessary information to design antennas for NXP NTAG ICs that are compatible with NFC compliant read / write devices.

Note: in RFID terminology an antenna is sometimes referred to as a coil.

### 1.1 Structure of the document

This document is subdivided into several parts.

Section 2 provides an overview of the theory of an antenna design.

Section 3 contains a description of various measurement methods to measure and calculate the equivalent circuits of an antenna. This section also provides a list of applicable instruments.

Section 4 provides a practical procedure for the development of rectangular, square or round (circular) antennas with copper wire, etched or printed antenna material.

Section 5 contains a link to the ISO/IEC 14443 standard that defines six antenna classes. NXP Semiconductors offers reference designs for "Class 4", "Class 5" and "Class 6" antennas that can be used to design an NFC tag based on the NTAG. This section also contains the Gerber files for the reference designs.

Some NTAG ICs, like the NTAG203F, NTAG213F, NTAG216F offer a so-called "Field detect" pin that can be used to activate an electronic device. (See [AN11141](#) and [AN11383](#) for description). On top NTAG I<sup>2</sup>C, NTAG I<sup>2</sup>C *plus* features an I<sup>2</sup>C interface to be connected to e.g. a microcontroller. NXP Semiconductors offers demo boards for the NTAG203F, NTAG216F, NTAG I<sup>2</sup>C and NTAG I<sup>2</sup>C *plus* that can be used to experience the functionality of the NTAG. Section 6 contains a description of the demo boards and also contains the Gerber files for the reference antenna designs.

Section 7 contains a list of abbreviations that are used throughout the document.

Customers that are familiar with antenna design can go straight to section 4 for the design of their antenna.

Note: Section 2, 3 and 4 are written for an antenna design on a label base, but are also applicable for PCB antennas. It is recommended to carry out read/ write tests with the tags and all different read / write devices that will be used with the tags.

## 2. Antenna theory

### 2.1 NTAG IC connections

The NTAG IC needs to be connected to the antenna with the pads  $L_A$  and  $L_B$

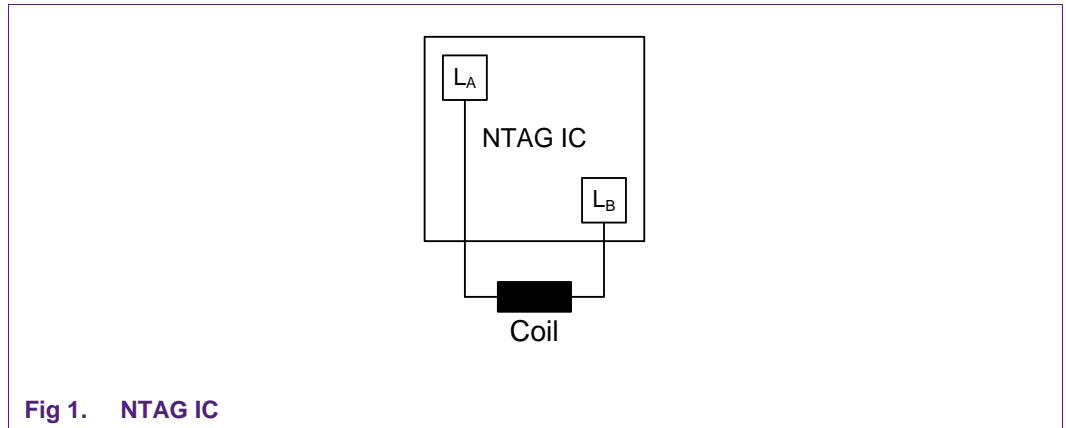

Fig 1. NTAG IC

#### 2.1.1 NTAG IC equivalent circuit

The following simple equivalent circuit describes the properties of the NTAG IC which are relevant for the antenna design.

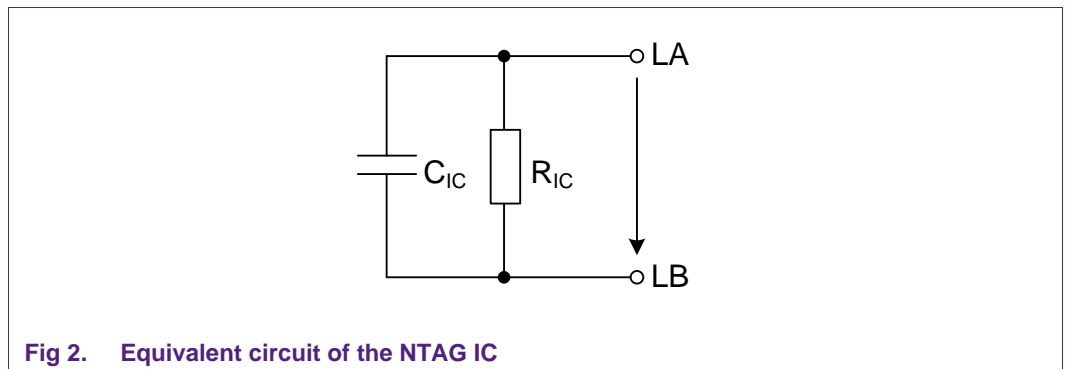

Fig 2. Equivalent circuit of the NTAG IC

#### 2.1.2 NTAG IC input capacitance $C_{IC}$

This electrical parameter of the NTAG IC is the most important factor for the antenna design. The form factor and the parameters of the antenna are affected by the input capacitance

The input capacitance depends on the applied chip voltage.

The following table specifies the value of this capacitance for the given type of NTAG IC.

**Table 1. Capacitance value of NTAG IC**

Type		$C_c$	Measurement conditions
NT2L1011G0DUx	NTAG210	17 pF	$V_{LA-LB} = 2 \text{ Vrms}, f = 13.56 \text{ MHz}^1$
NT2L1211G0DUx	NTAG212	17 pF	$V_{LA-LB} = 2 \text{ Vrms}, f = 13.56 \text{ MHz}^1$
NT2H0301F0DTx	NTAG203F	50 pF	$V_{LA-LB} = 2 \text{ Vrms}, f = 13.56 \text{ MHz}^1$
NT2H1311G0DUx	NTAG213	50pF	$V_{LA-LB} = 1.5 \text{ Vrms}, f = 13.56 \text{ MHz}$
NT2H1511G0DUx	NTAG215	50pF	$V_{LA-LB} = 1.5 \text{ Vrms}, f = 13.56 \text{ MHz}$
NT2H1611G0DUx	NTAG216	50pF	$V_{LA-LB} = 1.5 \text{ Vrms}, f = 13.56 \text{ MHz}$
NT2H1301F0DTL	NTAG213F	50pF	$V_{LA-LB} = 1.5 \text{ Vrms}, f = 13.56 \text{ MHz}$
NT2H1601F0DTL	NTAG216F	50pF	$V_{LA-LB} = 1.5 \text{ Vrms}, f = 13.56 \text{ MHz}$
NT3H1x01W0x	NTAG I <sup>2</sup> C 1k / 2k	50pF	$V_{LA-LB} = 2.4 \text{ Vrms}, f = 13.56 \text{ MHz}$
NT3H2x11W0x	NTAG I <sup>2</sup> C <i>plus</i> 1k / 2k	50pF	$V_{LA-LB} = 2.4 \text{ Vrms}, f = 13.56 \text{ MHz}$

<sup>1</sup> Measured with HP4285A LCR meter

## 2.2 Series and parallel equivalent circuits

### 2.2.1 Series equivalent circuit of the antenna

The antenna can be described by an inductance  $L_{sc}$  in series to a loss resistance  $R_{sc}$ . The antenna capacitance  $C_c$  is in parallel to this series circuit. This capacitance consists of the inter-turn capacitance and a possibly designed tag capacitance. The design of such a tag capacitance is not considered in this application note.

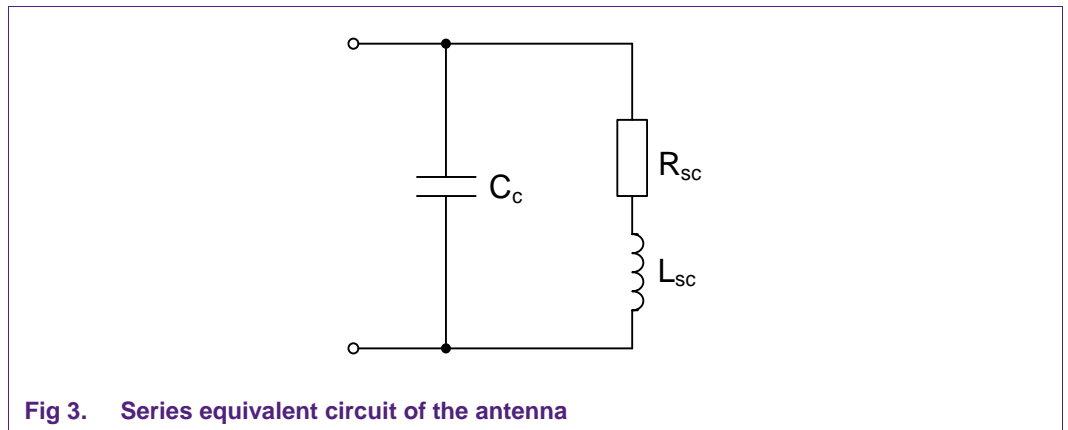

**Fig 3. Series equivalent circuit of the antenna**

The antenna quality factor is calculated by

$$Q_{sc} = \frac{2 \cdot \pi \cdot f_{op} \cdot L_{sc}}{R_{sc}}$$

with operating frequency  $f_{op} = 13.56$  MHz.

### 2.2.2 Parallel equivalent circuit of the antenna

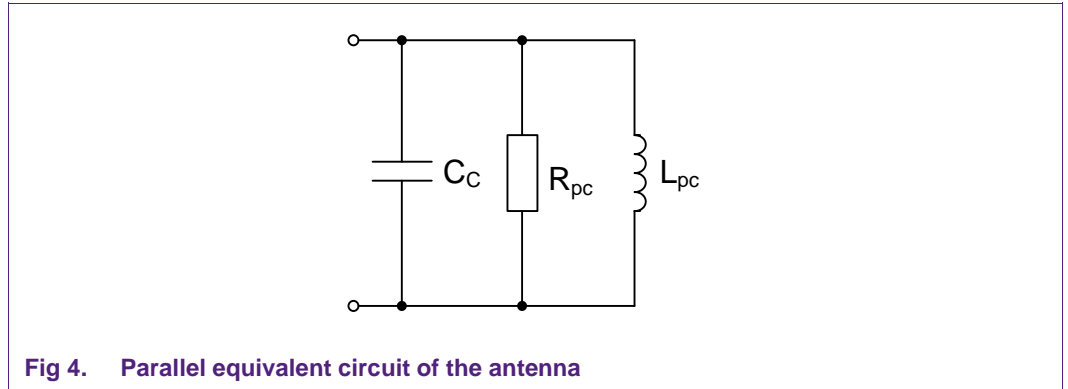

Fig 4. Parallel equivalent circuit of the antenna

The following applies:

$$L_{pc} = \frac{R_{sc}^2 + (2 \cdot \pi \cdot f_{op} \cdot L_{sc})^2}{(2 \cdot \pi \cdot f_{op})^2 \cdot L_{sc}} = L_{sc} \cdot \frac{1 + Q_{sc}^2}{Q_{sc}^2}$$

$$R_{pc} = \frac{R_{sc}^2 + (2 \cdot \pi \cdot f_{op} \cdot L_{sc})^2}{R_{sc}} = R_{sc} \cdot (1 + Q_{sc}^2)$$

$$Q_{pc} = \frac{R_{pc}}{2 \cdot \pi \cdot f_{op} \cdot L_{pc}} = Q_{sc}$$

For the further calculations the parallel equivalent circuit was chosen to simplify the resonance circuit. This makes calculation easier.

### 2.2.3 Equivalent circuit of the tag

The following figure shows the equivalent circuit of the whole tag.

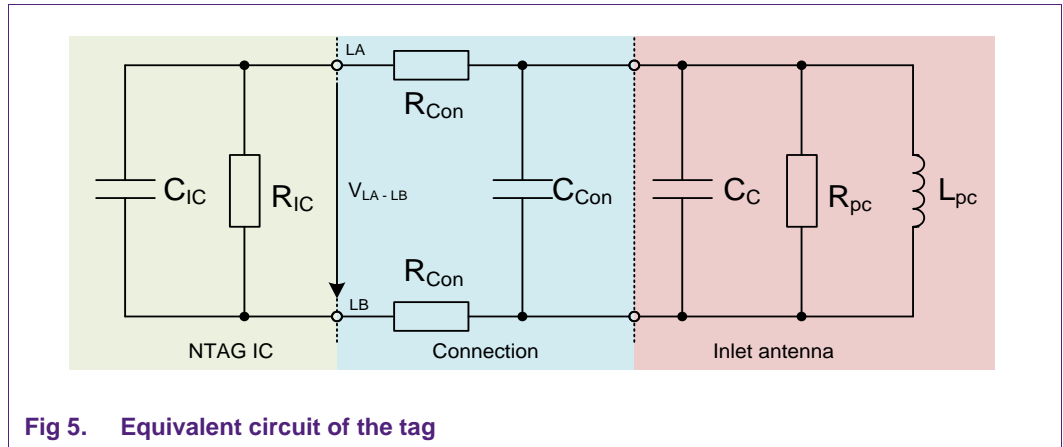

Fig 5. Equivalent circuit of the tag

The NTAG IC capacitance  $C_{IC}$  together with the antenna capacitance and the parasitic connection capacitance forms a resonance circuit with the inductance of the antenna.

The NTAG IC input resistance  $R_{IC}$  together with the loss resistance of the antenna and the connection resistance defines the quality factor of the tag. This quality factor has an effect on the threshold field strength of the tag and will be explained in the following sections.

$R_{Con}$  should be kept as low as possible in order not to influence the total parallel equivalent resistance of the tag  $R_{pl}$ . A relatively high connection resistance will decrease the total parallel quality factor of the tag and therefore decrease the transmission range.

$C_{Con}$  describes the increase of the total tag capacitance due to dielectric changes (under filler, adhesive ...) in the connection area when the chip is applied to the antenna.

For  $R_{Con} \ll 1\Omega$  the following simplified circuit can be used for the tag:

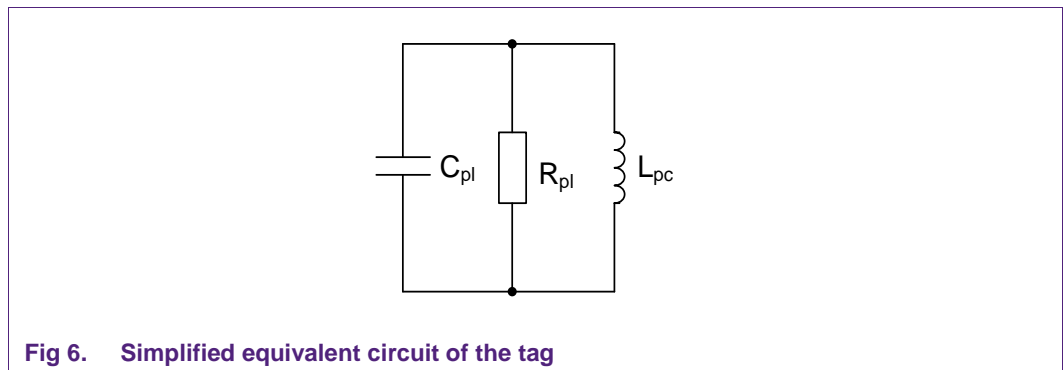

Fig 6. Simplified equivalent circuit of the tag

Parallel equivalent capacitance of the tag

$$C_{pl} = C_{IC} + C_{Con} + C_c$$

Parallel equivalent resistance of the tag

$$R_{pl} = \frac{R_{IC} \cdot R_{pc}}{R_{IC} + R_{pc}}$$

### 2.3 Resonance frequency and qualification factor of the tag

Based on the simplified equivalent circuit the resonance frequency  $f_R$  of the tag can be calculated with:

$$f_R = \frac{1}{2 \cdot \pi \cdot \sqrt{L_{pc} \cdot C_{pl}}}$$

The value of the NTAG IC input capacitance  $C_{IC}$  depends on the chip input voltage  $V_{LA-LB}$ . Therefore the resonance frequency of the tag changes with the IC input voltage.

Based on the simplified equivalent circuit (Fig 6) the quality factor  $Q$  of the tag at the operating frequency can be calculated with:

$$Q = \frac{R_{pl}}{2 \cdot \pi \cdot f_{op} \cdot L_{pc}}$$

The value of the NTAG IC input resistance  $R_{IC}$  depends on the chip input voltage  $V_{LA-LB}$ . Therefore also the quality factor of the tag changes with the IC input voltage.

#### 2.3.1 Threshold resonance frequency $f_{RT}$ and threshold quality factor $Q_T$

The threshold resonance frequency  $f_{RT}$  is the resulting resonance frequency for the minimum operating input voltage of the IC.

$V_{LA-LB}$  Minimal voltage level for NTAG IC operation

$$C_{plT} = C_{ICT} + C_{Con} + C_c$$

$C_{ICT}$  NTAG IC input capacitance for threshold condition

$C_{plT}$  Parallel equivalent capacitance of the tag for threshold condition

$C_{ICT}$  represents the NTAG IC input capacitance for minimal operating conditions and corresponds to the specified typical value.

$$f_{RT} = \frac{1}{2 \cdot \pi \cdot \sqrt{L_{pc} \cdot C_{plT}}}$$

$$R_{plT} = \frac{R_{ICT} \cdot R_{pc}}{R_{ICT} + R_{pc}}$$

$R_{ICT}$  NTAG IC input resistance for threshold condition

$R_{pIT}$  Parallel equivalent resistance of the tag for threshold condition

$R_{ICT}$  represents the NTAG IC input resistance for the minimal operating conditions and corresponds to the shown typical value.

$$Q_T = \frac{R_{pIT}}{2 \cdot \pi \cdot f_{RT} \cdot L_{pc}}$$

2.4 Threshold field strength  $H_T$

This section gives formulas to calculate the threshold field strength  $H_T$  which is significant for the transmission range. The influence of the threshold resonance frequency  $f_{RT}$  and the antenna quality factor  $Q_{pc}$  on this field strength is figured out.

The voltage on the IC generated by the magnetic field of the reader with antenna current  $I_1$  is given by:

$$V_{LA-LB} = \frac{2 \cdot \pi \cdot f \cdot M}{\left( \left( 1 - \left( \frac{f}{f_R} \right)^2 \right)^2 + \left( \frac{2 \cdot \pi \cdot f \cdot L_{pc}}{R_{pl}} \right)^2 \right)^{1/2}} \cdot I_1$$

With the assumption that the turns of the tag antenna are concentrated on the average antenna dimensions, the threshold field strength for NTAG IC operation can be calculated with:

$$H_T = \frac{\left( \left( 1 - \left( \frac{f}{f_{RT}} \right)^2 \right)^2 + \left( \frac{2 \cdot \pi \cdot f \cdot L_{pc}}{R_{plT}} \right)^2 \right)^{1/2}}{2 \cdot \pi \cdot f \cdot \mu_0 \cdot N_c \cdot A_c} \cdot V_{LA-LB \min}$$

The following figure shows the behavior of threshold field strength  $H_T$  versus the frequency  $f$  of the inducing magnetic field for a tag with the threshold resonance frequency  $f_{RT}$ .

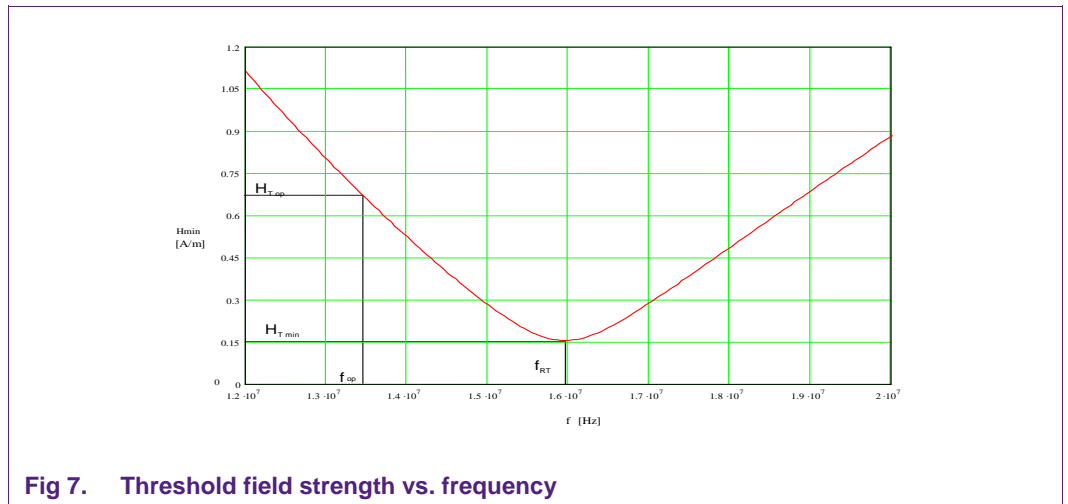

Fig 7. Threshold field strength vs. frequency

The curve of the threshold field strength reaches its minimum at the threshold resonance frequency  $f_{RT}$  of the tag. For  $f=f_{RT}$  the minimal threshold field strength  $H_{T \min}$  results in:

$$H_{T\min} = \frac{L_{pc}}{\mu_0 \cdot N_c \cdot A_c \cdot R_{pIT}} \cdot V_{LA-LB\min}$$

At the operating frequency  $f_{op}$  the threshold field strength results in:

$$H_{Top} = \frac{\left( \left( 1 - \left( \frac{f_{op}}{f_{RT}} \right)^2 \right)^2 + \left( \frac{2 \cdot \pi \cdot f_{op} \cdot L_{pc}}{R_{pIT}} \right)^2 \right)^{1/2}}{2 \cdot \pi \cdot \mu_0 \cdot f_{op} \cdot N_c \cdot A_c} \cdot V_{LA-LB\min}$$

Lowest operating field strength is reached if  $f_{RT} = f_{op} = 13.56$  MHz resulting in  $H_T = H_{T\min}$ .

## 3. Antenna measurement methods

### 3.1 Antenna characterization

The equivalent circuit of the antenna (without IC) can be determined by using the following measuring instruments with associated measuring principals.

#### 3.1.1 Impedance analyzer with equivalent circuit calculation

The following instruments are examples of equipment that can be used to determine the value of the parameter of a serial or parallel equivalent circuit by measuring the magnitude and the phase of the impedance of the connected antenna.

Instruments: HP 4194A – Impedance analyzer  
HP 4294A – LCR impedance analyzer  
HP 4195A – Network/ Spectrum analyzer  
HP 4295A – LCR meter

The antenna under test must be connected to the analyzer by using an appropriate test fixture that does not influence the antenna parameters (no metal parts near the antenna etc.).

Before each measurement the analyzer must be calibrated (open, short and load compensation at the calibration plane) and the test fixture compensated (open, short compensation at the connection points) according to the instruments manual.

Settings:  $|Z|$ ,  $\ominus$   
Center frequency: 13.56MHz  
Span:  $\pm 4$  MHz

Parallel equivalent circuit is used for measurement. The values can then be used for the antenna design procedure.

#### 3.1.2 Method for ISO/IEC 7810 ID-1 sized card

For ID-1 sized cards a measurement method is available.

##### Measurement principle:

A measurement (or calibration) antenna has to be connected to the instrument. A short-calibration has to be performed with this measurement antenna connected to the terminals of the instrument.

The measuring antenna itself is described in section 6.1 of [\[1\]](#) and meets the following requirements.

- Roughly the same dimensions as the calibration antenna
- 1 turn
- Low parasitic capacitance
- High quality factor;  $Q \sim 40$

The measurement of the bare short-compensated measuring antenna (no tag antenna next to it) shows very low impedance. For tag characterization it has to be positioned without any distance and covering the measuring antenna completely. The measurement of R and X shows a well-defined maximum of the resistance. The resonance frequency of the tag is found at the maximum of R.

Resonance frequency:  $f_R @ / R = \text{maximum}$

**Measurement preparations:**

- The measuring antenna has to be connected to the test fixture of the instrument
- A short correction of the measuring antenna has to be performed and switched on
- Settings: R, X, frequency sweep (if using LCR meter this has to be done manually or by software)
- Output power has to be set to 15mA.

### 3.1.3 Impedance analyzer or LCR meter

**Measurement principle:**

A measurement antenna has to be connected to the instrument. A short-calibration has to be performed with this measurement antenna connected to the terminals of the instrument.

The measuring antenna has to meet the following requirements:

- Roughly the same dimension as the card antenna
- 1 turn
- Low parasitic capacitance
- High quality factor;  $Q \sim 40$

The measurement of the bare compensated measuring antenna (no tag antenna next to it) shows very low impedance. For tag characterization it has to be positioned close to the measuring antenna (approx. 1cm distance). The measurement (R, X) of the measuring antenna shows a well-defined maximum of the resistance. The resonance frequency is found at this maximum of R.

Resonance frequency:  $f_R @ / R = \text{maximum}$

**Measurement preparations:**

- The measuring antenna has to be connected to the test fixture of the instrument
- A short correction of the measuring antenna has to be performed and switched on
- Settings: R, X, frequency sweep (for LCR meter this has to be done manually or by software)
- Use highest possible output power of the measurement equipment

### 3.1.4 Reference measurement using capacitor

This measurement generally only verifies the antenna, because there is no IC connected. It can be used to verify the tuning of a tag.

**Measurement principle:**

Instead of a tag consisting of antenna with NTAG IC, now a dummy tag consisting of antenna with reference capacitor is used.

The reference capacitor should meet to following requirements:

- Value of reference capacitor optimal is the nominal capacitance of the used NTAG IC
- High quality capacitors have to be used; capacitors with a low tolerance

A measuring antenna has to be connected to the instrument. A short-calibration has to be performed with this measuring antenna connected to the terminals of the instrument.

The measuring antenna has to meet the following requirements:

- Roughly the same dimension as the card antenna
- 1 turn
- Low parasitic capacitance
- High quality factor;  $Q \sim 40$

The measurement of the bare compensated measuring antenna (no tag antenna next to it) shows very low impedance. The tag has to be positioned close to the measuring antenna (approx. 1cm distance). The measurement (R, X) of the measuring antenna shows a well-defined maximum of the resistance. The resonance frequency is found at this maximum of R.

Resonance frequency:  $f_R @ / R = \text{maximum}$

**Measurement preparations:**

- The measuring antenna has to be connected to the test fixture of the instrument
- A short correction of the measuring antenna has to be performed and switched on

Settings: R, X, frequency sweep

### 3.1.5 Minimum field strength measurement

With this measurement the frequency is determined where the tag can be operated with the lowest field strength. This frequency is called resonance frequency.

This measurement is performed with the measurement configuration as it is used in [\[1\]](#).

## 4. Antenna design procedure

### 4.1 Design flow

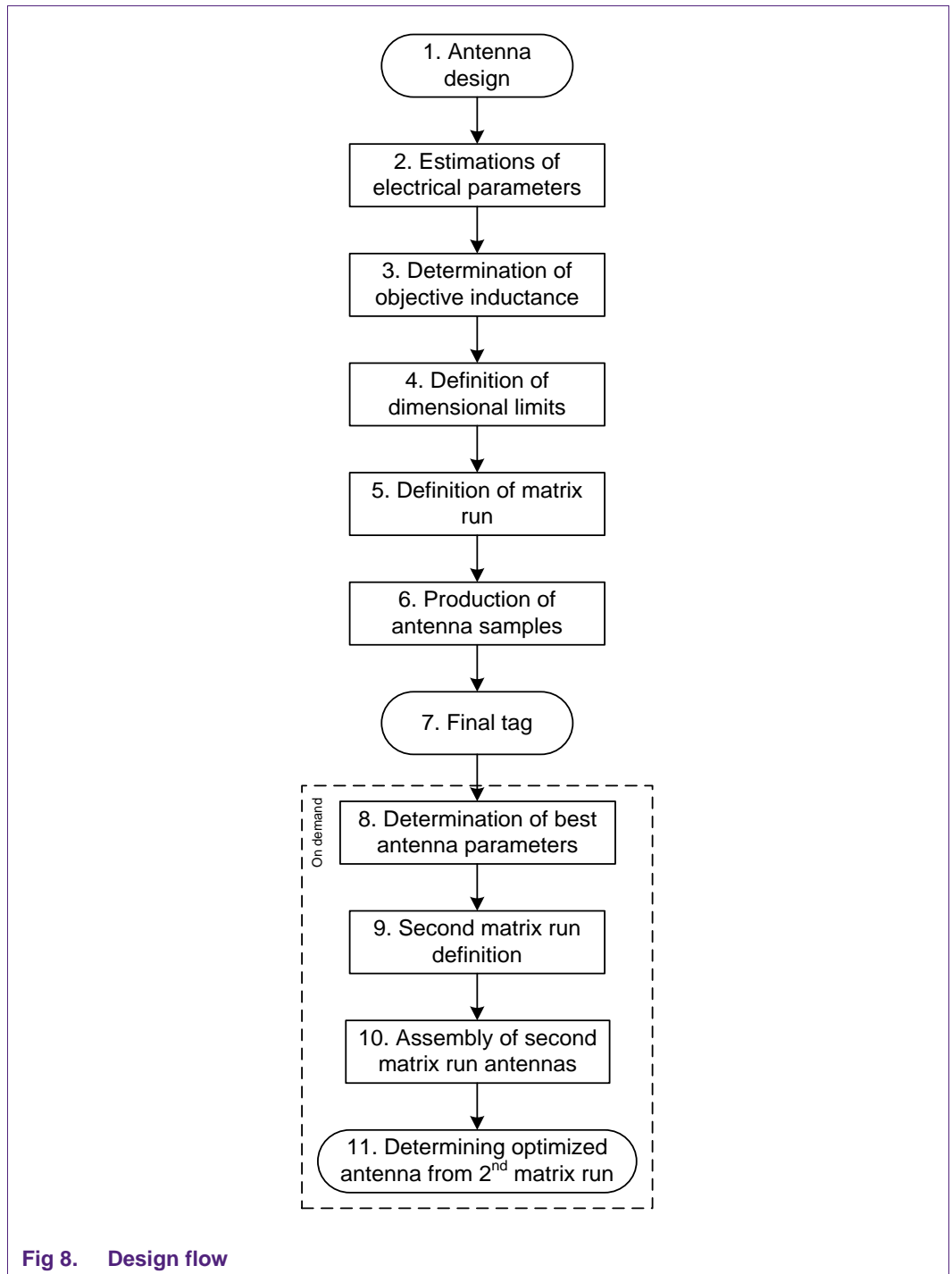

Fig 8. Design flow

## 4.2 Estimation of electrical parameters

### 4.2.1 Ideal threshold frequency $f_{IDEAL}$ determination

Based on the application it is necessary to determine what resonance frequency the inlet should be tuned to.

For single tag operation a tuning slightly above 13.56 MHz would lead to maximum read-/write distance. Due to manufacturing tolerances a nominal frequency of 14.5 MHz for single tag operation is recommended.

### 4.2.2 Estimation of the antenna capacitance $C_c$

In order to be able to calculate the approximate objective inductance  $L_o$  of the antenna, it is necessary to estimate the capacitance  $C_c$  of the antenna. This capacitance can be split up into the always existing antenna inter turn capacitance  $C_{it}$ , the additional capacitance due to possibly realized bridge  $C_{br}$  and a possibly designed on tag capacitance  $C_{in}$ .

The antenna inter turn capacitance  $C_{it}$  is dependent upon the technology used for the antenna manufacturing. The following table shows the estimated values for some often used technologies.

**Table 2. Antenna inter turn capacitance**

Antenna manufacturing technology	$C_{it}$ [pF]
Wired	5 – 7
Etched	2 – 4
Printed	2 – 4

The capacitance of a possibly realized bridge  $C_{br}$  depends on the bridge length and bridge width.

Estimated value:  $C_{br} = 1 - 5$  pF

An additional capacitance realized on the tag  $C_{in}$  depends on the capacitor area. This capacitance is difficult to estimate, so it is recommended to make a measurement of this tag capacitor.

$$C_c = C_{it} + C_{br} + C_{in}$$

### 4.2.3 Estimation of the connection capacitance $C_{Con}$

The connection capacitance can be estimated by choosing a value out of the following range:

$$C_{Con} = 0.5 - 2$$
 pF

**4.2.4 Calculation of objective antenna inductance  $L_o$  based on an estimated tag capacitance  $C_{pIT}$**

$$C_{pIT} = C_{ICT} + C_{Con} + C_c$$

With  $C_{ICT} = 50$  pF

$$L_o = \frac{1}{(2 \cdot \pi \cdot f_{RT})^2 \cdot C_{pIT}}$$

With  $f_{RT} = f_{ideal}$

**4.3 Determination of objective inductance  $L_o$**

**4.3.1 Rectangular (square) antennas**

**4.3.1.1 Calculation of inductance**

The inductance of the antenna based on geometrical parameters estimates to:

$$L_{calc} = \frac{\mu_0}{\pi} \cdot [x_1 + x_2 - x_3 + x_4] \cdot N_c^p$$

with:

$$d = \frac{2 \cdot (t + w)}{\pi}$$

$$a_{avg} = a_o - N_c \cdot (g + w)$$

$$b_{avg} = b_o - N_c \cdot (g + w)$$

$$x_1 = a_{avg} \cdot \ln \left[ \frac{2 \cdot a_{avg} \cdot b_{avg}}{d \cdot (a_{avg} + \sqrt{a_{avg}^2 + b_{avg}^2})} \right]$$

$$x_2 = b_{avg} \cdot \ln \left[ \frac{2 \cdot a_{avg} \cdot b_{avg}}{d \cdot (b_{avg} + \sqrt{a_{avg}^2 + b_{avg}^2})} \right]$$

$$x_3 = 2 \cdot [a_{avg} + b_{avg} - \sqrt{a_{avg}^2 + b_{avg}^2}]$$

$$x_4 = \frac{a_{avg} + b_{avg}}{4}$$

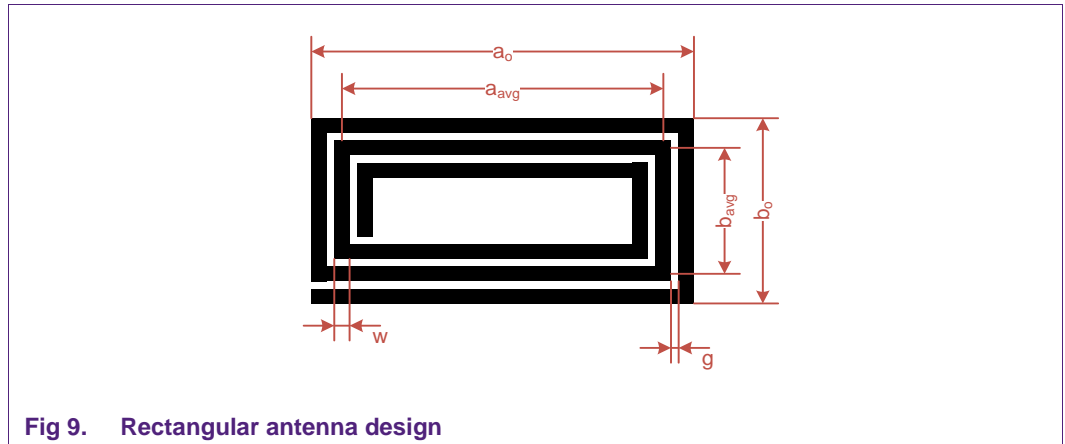

Fig 9. Rectangular antenna design

Table 3. Rectangular antenna parameter

Parameters	Description
$a_o, b_o$	Overall dimensions of the antenna
$a_{avg}, b_{avg}$	Average dimensions of the antenna
$t$	Track thickness
$w$	Track width
$g$	Gap between the tracks
$N_c$	Number of turns
$d$	Equivalent diameter of the track
$p$	Turn exponent

4.3.2 Round antennas

The inductance of the antenna based on geometrical parameters estimates to:

$$L_{calc} [nH] = 2 \cdot l \cdot \left[ \ln \frac{l}{d} - 1,07 \right] \cdot N^p$$

$$l = D_{avg} \cdot \pi$$

$$D_{avg} = D_o - N \cdot (g + w)$$

$$d = \frac{2 \cdot (w + g)}{\pi}$$

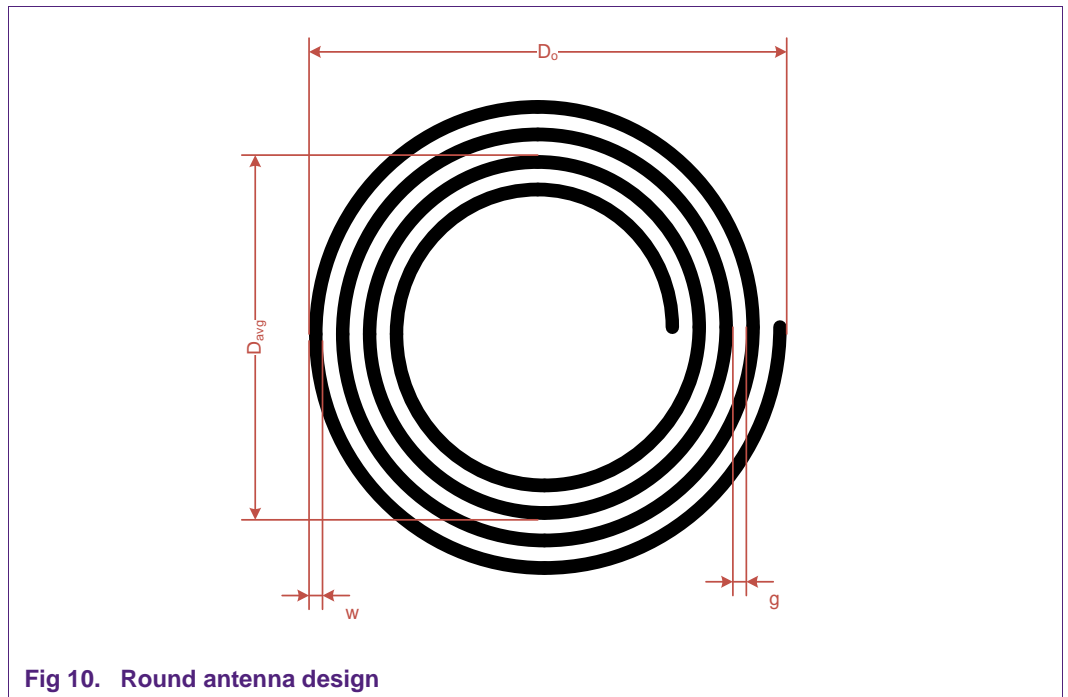

Fig 10. Round antenna design

Table 4. Round antenna parameters

Parameter	Description
$D_o$	Antenna diameter [cm]
$t$	Track thickness
$w$	Track width
$g$	Gap between the tracks
$N_c$	Number of turns
$d$	Equivalent diameter of the track
$p$	Turn exponent
$D_{avg}$	Average antenna diameter [cm]
$l$	Average antenna circumference

## 4.4 Determination of dimensional limits

### 4.4.1 Rectangular (square) antennas

#### 4.4.1.1 Maximum antenna dimensions $a_{\max}$ , $b_{\max}$

The maximum dimensions of the antenna  $a_{\max}$  and  $b_{\max}$  are determined by the application which the tag is designed for.

Therefore the starting point for the calculations is always:

$$a_0 = a_{\max}$$

$$b_0 = b_{\max}$$

The actual overall dimension of the antenna  $a_0$  and  $b_0$  can also be smaller than  $a_{\max}$  and  $b_{\max}$  in some cases (large tags) but the product  $A_c \cdot N_c$  should be kept always as high as possible (see “minimal threshold field strength” in section 2.4)!

$$A_c = a_{\text{avg}} \cdot b_{\text{avg}}$$

The active antenna  $A_{\text{active}}$  area is the product of average antenna area  $A_c$  and the number of turns  $N_c$ .

$$A_{\text{active}} = A_c \cdot N_c$$

#### 4.4.1.2 Gap between the tracks $g$

The minimal gap between the tracks  $g_{\min}$  is defined by the antenna production process. To get the highest possible antenna area:

$$g = g_{\min}$$

#### 4.4.1.3 Track thickness $t$ and track width $w$

For aluminum and copper antennas a track thickness of  $t \geq 30\mu\text{m}$  should give a sufficient quality factor even for a small track width  $w$ .

For printed antennas the track thickness should be chosen as high as possible to get highest possible quality factors.

The track width  $w$  remains as fit-parameter for the calculation of the inductance  $L_{\text{calc}}$ . It is recommended to choose the track width  $w$  not too small as it influences the quality factor  $Q_{\text{pc}}$  and a variation of the track width  $w$  is needed for the second matrix run as well.

#### 4.4.1.4 Estimation of turn exponent $p$

Under the assumption that all turns are concentrated on the outline of the antenna, so all magnetic flux passes the enclosed area of all turns (no stray field) and the magnetic coupling between the turns is 100%, the inductance is proportional to  $N_c^2$ .

As this is not possible to realize the following table gives estimated values for the turn exponent  $p$  for different antenna manufacturing technologies.

**Table 5. Turn exponent  $p$**

Antenna manufacturing technology	$p$
Wired	1.8 – 1.9
Etched	1.75 – 1.85
Printed	1.7 – 1.8

#### 4.4.2 Round antennas

##### 4.4.2.1 Maximum antenna dimension $D_{max}$

The maximum dimension of the antenna  $D_{max}$  is determined by the application the tag is designed for.

Therefore the starting point for the calculation is always:

$$D_o = D_{max}$$

The actual overall dimension of the antenna  $D_o$  can also be smaller than  $D_{max}$  in some cases (large tags) but the product  $A_c \cdot N_c$  should be kept always as high as possible.

$$A_c = D_{avg}^2 \cdot \frac{\pi}{4}$$

##### 4.4.2.2 Gap between tracks $g$

The minimal gap between the tracks  $g_{min}$  is defined by the antenna production process.

To get the highest possible average antenna area:

$$g = g_{min}$$

##### 4.4.2.3 Track thickness $t$ and track width $w$

For aluminum and copper antenna a track thickness of  $t \geq 30\mu m$  should give a sufficient quality factor even for a small track width  $w$ .

For printed antennas the track thickness should be chosen as high as possible to get the highest possible quality factor.

The track width  $w$  remains as fit-parameter for the calculation of the inductance  $L_{calc}$ . It is recommended to choose the track width  $w$  not too small as it influences the quality factor  $Q_{pc}$  and a variation of the track width  $w$  is needed for the second matrix run as well.

##### 4.4.2.4 Estimation of turn exponent $p$

Under the assumption that all turns are concentrated on the outline of the antenna, so all magnetic flux passes the enclosed area of all turns (no stray field) and the magnetic coupling between the turns is 100%, the inductance is proportional to  $N_c^2$ .

As this is not possible to realize the following table gives estimated values for the turn exponent  $p$  for different antenna manufacturing technologies.

**Table 6. Turn exponent  $p$**

Antenna manufacturing technology	$p$
Wired	1.8 – 1.9
Etched	1.75 – 1.85
Printed	1.7 – 1.8

## 4.5 Definition of matrix run

### 4.5.1 Rectangular (square) antennas

#### 4.5.1.1 Matrix run definition

The following values have to be fixed before starting the matrix run calculations:

$L_o, p, a_{max}, b_{max}, t, g$

The calculation of the inductance  $L_o$  is based on estimated values and also the calculation of the antenna parameters at this time can only be made approximately. Therefore the inductance of the matrix run antennas should be varied within  $\pm 20\%$  of the estimated objective inductance  $L_o$ .

$i$  ... first matrix run antenna number

**Table 7. First matrix run**

$i$	1	2	3	4	5
$L_{calc, i}$	$0.8 L_o$	$0.9 L_o$	$L_o$	$1.1 L_o$	$1.2 L_o$
$a_{o, i}$					
$b_{o, i}$					
$N_{c, i}$					
$w_i$					

The antenna parameters  $a_{o, i}, b_{o, i}, N_{c, i}$  and  $w_i$  must be experimentally varied until  $L_{calc, i}$  is equal to the given percentage of the estimated objective inductance  $L_o$ . During this antenna parameter determination it must be always attempted to keep the product  $A_{c,i} \cdot N_{c,i}$  as high as possible!

### 4.5.2 Round antennas

#### 4.5.2.1 Matrix run definition

The following values have to be fixed before starting the matrix run calculations:

$L_o, p, D_{max}, t, g$

The calculation of the inductance  $L_o$  is based on estimated values and also the calculation of the antenna parameters at this time can only be made approximately.

Therefore the inductance of the matrix run antennas should be varied within  $\pm 20\%$  of the estimated objective inductance  $L_o$ .

$i$  ... first matrix run antenna number

**Table 8. First matrix run**

$i$	1	2	3	4	5
$L_{calc, i}$	$0.8 L_o$	$0.9 L_o$	$L_o$	$1.1 L_o$	$1.2 L_o$
$D_{o, i}$					
$N_{c, i}$					
$w_i$					

The antenna parameters  $D_{o, i}$ ,  $N_{c, i}$  and  $w_i$  must be experimentally varied until  $L_{calc, i}$  is equal to the given percentage of the estimated objective inductance  $L_o$ . During this antenna parameter determination it must be always attempted to keep the product  $A_{c, i} \cdot N_{c, i}$  as high as possible!

#### 4.6 Final antenna/ tag

To decide which antenna fits the requirements of resonance frequency best, it is recommended to measure the tag resonance frequency and compare with the targets defined at the beginning ( $f_{ideal}$ ).

For this measurement the ISO setup or a measurement as described in 3.1.3 or 3.1.4 is recommended.

**Table 9. Result table**

$k$	1	2	3	4	5
$f_R$					

##### 4.6.1 Choosing the best antenna

Calculate the difference between the measured resonance frequency  $f_R$  and the ideal resonance frequency  $f_{ideal}$

$$\Delta f_{Ideal-R, j} = \left| f_{Ideal} - f_{R, j} \right|$$

**Table 10. Optimum antenna**

$j$	1	2	3	4	5
$f_{ideal-R, j}$					

The optimum antenna is the antenna that's nearest to  $f_{ideal}$ .

$$\Delta f_{Ideal-R,j} = Minimum$$

**Table 11. Summary table of parameters of antenna *j* (rectangular)**

Parameter	Value
<i>J</i>	
<i>L<sub>pc,j</sub></i>	
<i>C<sub>c,j</sub></i>	
<i>a<sub>o,j</sub></i>	
<i>b<sub>o,j</sub></i>	
<i>N<sub>c,j</sub></i>	
<i>w<sub>j</sub></i>	

**Table 12. Summary table of parameters of antenna *j* (round)**

Parameter	Value
<i>J</i>	
<i>L<sub>pc,j</sub></i>	
<i>C<sub>c,j</sub></i>	
<i>D<sub>o,j</sub></i>	
<i>N<sub>c,j</sub></i>	
<i>w<sub>j</sub></i>	

## 4.7 Determination of best antenna parameters

If there is no antenna fitting to your requirements up to here, it is possible to do a second optimization step – a second matrix run.

### 4.7.1 Rectangular antennas

#### 4.7.1.1 Equivalent circuit measurement and evaluation of antennas

The parallel equivalent circuit of the matrix run antennas must be determined (see also section 3).

**Table 13. Measurement results**

<i>i</i>	1	2	3	4	5
<i>C<sub>c,i</sub></i>					
<i>L<sub>pc,i</sub></i>					

<i>i</i>	1	2	3	4	5
$R_{pc,i}$					
$Q_{pc,i}$					

**4.7.1.2 Calculation of objective antenna inductance  $L_{o,i}$**

The value of the antenna capacitance  $C_{c,i}$  is determined for all antennas now. These values are used to calculate the objective antenna inductance  $L_{o,i}$  for all antennas.

$$C_{pIT,i} = C_{ICT} + C_{Con} + C_{c,i}$$

$$L_{o,i} = \frac{1}{(2 \cdot \pi \cdot f_{RT})^2 \cdot C_{pIT,i}}$$

with  $f_{RT} = f_{ideal}$

**4.7.1.3 Minimal difference between  $L_{pc,i}$  and  $L_{o,i}$**

The optimum antenna of the matrix run is the one where the difference of measured inductance  $L_{pc,i}$  and objective inductance  $L_{o,i}$  is a minimum.

$$\Delta L_i = |L_{pc,i} - L_{o,i}|$$

**Table 14. Inductance comparison**

<i>i</i>	1	2	3	4	5
$L_{pc,i}$					
$L_{o,i}$					
$\Delta L_i$					

The antenna number *l* with minimum  $\Delta L_i$ :  $j=i$

*j* ... Antenna number with minimum  $\Delta L_j$

**Table 15. Parameter summary**

Parameter	Value
<i>j</i>	
$L_{pc,j}$	
$C_{c,j}$	

Parameter	Value
$a_{o,j}$	
$b_{o,j}$	
$N_{c,j}$	
$w_j$	

Usually the antenna chosen here is the final antenna design for NTAG designs. If more exact tuning is necessary for the application, this antenna is the starting point for the second matrix calculation.

**4.7.1.4 Determination of turn exponent  $p$**

For the chosen antenna  $j$  the precise turn exponent  $p$  can be calculated now.

$$a_o = a_{o,j}$$

$$b_o = b_{o,j}$$

$$L_{pc,j} = L_{calc} = \frac{\mu_0}{\pi} \cdot [x_1 + x_2 + x_3 + x_4] \cdot N_{c,j}^p$$

$$p = \frac{\ln\left(\frac{L_{pc,j} \cdot \pi}{\mu_0 \cdot [x_1 + x_2 + x_3 + x_4]}\right)}{\ln N_{c,j}}$$

**4.7.2 Round antennas**

**4.7.2.1 Equivalent circuit measurement and evaluation of antennas**

The parallel equivalent circuit of the matrix run antennas must be determined (see also section 3).

**Table 16. Measurement results**

$i$	1	2	3	4	5
$C_{c,i}$					
$L_{pc,i}$					
$R_{pc,i}$					
$Q_{pc,i}$					

**4.7.2.2 Calculation of the objective antenna inductance  $L_{o,i}$**

The value of the antenna capacitance  $C_{c,i}$  is determined for all antennas now. These values are used to calculate objective antenna inductance  $L_{o,i}$  for all antennas.

$$C_{pIT,i} = C_{ICT} + C_{Con} + C_{c,i}$$

$$L_{o,i} = \frac{1}{(2 \cdot \pi \cdot f_{RT})^2 \cdot C_{pIT,i}}$$

with  $f_{RT} = f_{ideal}$

**4.7.2.3 Minimal difference between  $L_{pc,i}$  and  $L_{o,i}$**

The optimum antenna of the matrix run is the one where the difference of measured inductance  $L_{pc,i}$  and objective inductance  $L_{o,i}$  is a minimum.

$$\Delta L_i = |L_{pc,i} - L_{o,i}|$$

**Table 17. Inductance comparison**

<i>i</i>	1	2	3	4	5
$L_{pc,i}$					
$L_{o,i}$					
$\Delta L_i$					

The antenna number *i* with minimum  $\Delta L_i$ :  $j = i$   
*j* ... Antenna number with minimum  $\Delta L_j$

**Table 18. Parameter summary**

Parameter	Value
<i>j</i>	
$L_{pc,j}$	
$C_{c,j}$	
$D_{o,j}$	
$N_{c,j}$	
$w_j$	

Usually the antenna chosen here is the final antenna design for NTAG designs. If more exact tuning is necessary for the application, this antenna is the starting point for the second matrix calculation.

**4.7.2.4 Determination of turn exponent *p***

For the chosen antenna *j* the precise turn exponent *p* can be calculated now.

$$D_o = D_{o,j}$$
$$p = \frac{\ln \left( \frac{L_{pc,j}}{2 \cdot l_j \cdot \left\{ \ln \left( \frac{l_j}{d_j} \right) \cdot 1,07 \right\}} \right)}{\ln N_{c,j}}$$

**4.8 Second matrix run definition**

**4.8.1 Rectangular antennas**

$$a_o = a_{o,j}$$

$$b_o = b_{o,j}$$

$$L_{calc} = \frac{\mu_0}{\pi} \cdot [x_1 + x_2 + x_3 + x_4] \cdot N_{c,j}^p$$

**4.8.2 Circular antennas**

$$D_o = D_{o,j}$$

$$L_{calc} [nH] = 2 \cdot l \cdot \left[ \ln \frac{l_j}{d_j} - 1,07 \right] \cdot N_{c,j}^p$$

**4.8.3 Table for optimized antennas**

The calculation of the inductance  $L_{o,j}$  is still based on an estimated connection capacitance  $C_{con}$  and also the antenna parameters have an influence on each other giving a nonlinear system. Therefore the inductance of the second matrix run antennas should be varied within  $\pm 8\%$  of the objective inductance  $L_{o,j}$ .

$k$  ... second matrix run antenna number

**Table 19. Second matrix run**

<b>k</b>	<b>1</b>	<b>2</b>	<b>3</b>	<b>4</b>	<b>5</b>
$L_{calc,k}$	0.92 $L_{o,j}$	0.96 $L_{o,j}$	$L_{o,j}$	1.04 $L_{o,j}$	1.08 $L_{o,j}$
$w_k$					

Only the antenna parameter track width  $w_k$  should be varied until  $L_{calc,k}$  is equal the given percentage of objective inductance  $L_{o,j}$ . In order to keep the accuracy of the calculation on a high level the overall dimension  $a_o$ ,  $b_o$ ,  $D_o$  and the gap between the tracks  $g$  as well as the track thickness  $t$  should not be varied anymore.

## 4.9 Determining optimized antenna from second matrix run

### 4.9.1 Tag with IC

The unloaded resonance frequency  $f_R$  of the second matrix run tags should be characterized (see section 3).

A tag must be determined where the value of the measured threshold resonance frequency  $f_{RT,k}$  is closest to the optimal value. The used track width  $w_k$  of this tag defines the optimum track width for the antenna.

Table 20. Result table

$k$	1	2	3	4	5
$f_R$					

### 4.9.2 Choosing the best antenna

Calculate the difference between the measured resonance frequency  $f_{RT}$ , and the ideal resonance frequency  $f_{ideal}$ :

$$\Delta f_{ideal-R,k} = \left| f_{ideal} - f_{R,k} \right|$$

Table 21. Optimum antenna

$k$	1	2	3	4	5
$f_{ideal-RTnom,k}$					

The optimum antenna is the antenna that's nearest to  $f_{ideal}$ .

$$\Delta f_{ideal-R,k} = \textit{Minimum} \tag{1}$$

Table 22. Summary table of parameters of antenna  $k$

Parameter	Value
$k$	
$L_{pc,k}$	
$C_{c,k}$	
$a_{o,k}$	
$b_{o,k}$	
$N_{c,k}$	

Parameter	Value
$W_k$	

#### 4.10 Antenna calculation tools

NXP provides their customers an excel-based calculation tool for rectangular and round antennas, to make the antenna design easier.

The rectangular antenna calculation tool is described in [NTAG\\_CDG\\_SQUARE\\_V1.xlsx](#)

Round antenna calculation is described in [NTAG\\_CDG\\_ROUND\\_V1.xlsx](#)

## 5. Antenna classes

### 5.1 Class definition

In [3] and [5] six antenna classes are defined (Class1 – Class6). All six classes describe different form factors and sizes.

For a NFC tag, NXP recommend to use “Class 3”, “Class 4”, “Class 5” or “Class 6” antennas.

#### 5.1.1 “Class 3” antenna

A “Class 3” antenna shall fulfill the following requirements.

The antenna shall be located within a zone defined either:

- External rectangle: 50 x 40mm
- Internal rectangle: 35 x 24mm, centered in the external rectangle, with 3mm corner radii

or

- external circle with diameter 50mm
- internal circle with diameter 32mm, concentric with the external circle

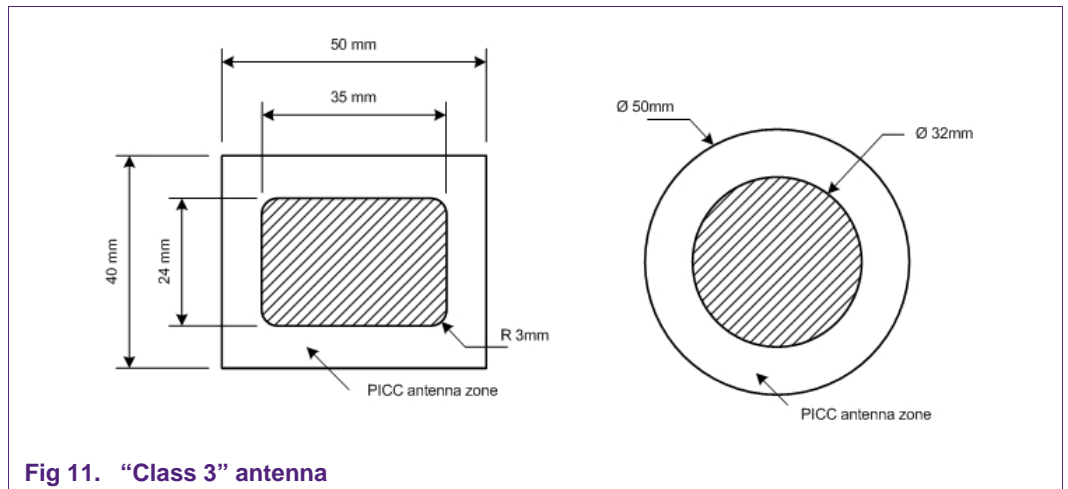

#### 5.1.2 “Class 4” antenna

A “Class 4” antenna shall fulfill the following requirements.

The antenna shall be located within a zone defined either:

- External rectangle: 50 x 27mm
- Internal rectangle: 35 x 13mm, centered in the external rectangle, with 3mm corner radii

or

- external circle with diameter 41mm
- internal circle with diameter 24mm, concentric with the external circle

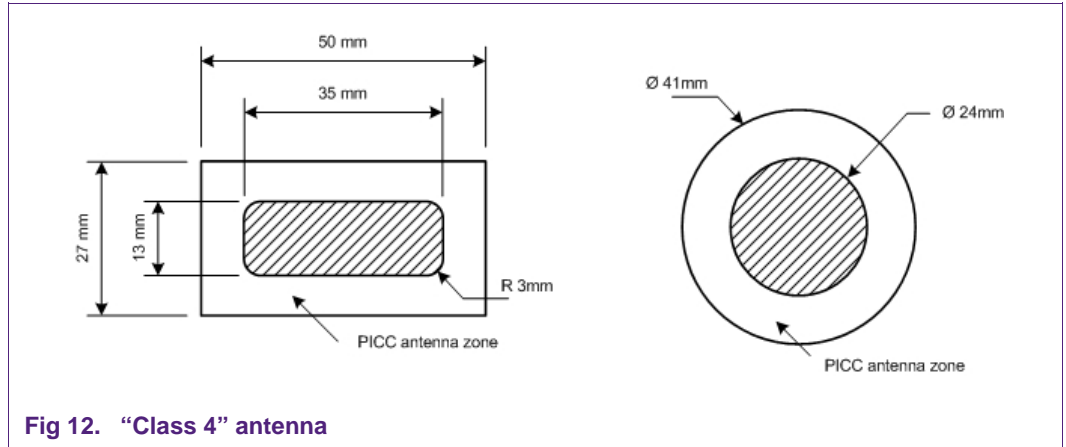

Fig 12. "Class 4" antenna

### 5.1.3 "Class 5" antenna

A "Class 5" antenna shall fulfill the following requirements.

The antenna shall be located within a zone defined either:

- External rectangle: 40,5 x 24,5mm
- Internal rectangle: 25 x 10mm, centered in the external rectangle, with 3mm corner radii

or

- external circle with diameter 35mm
- internal circle with diameter 18mm, concentric with the external circle

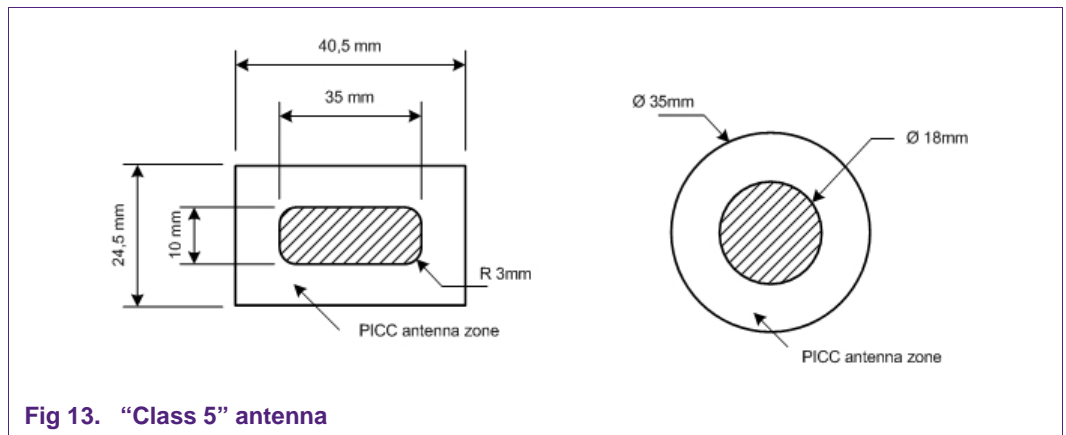
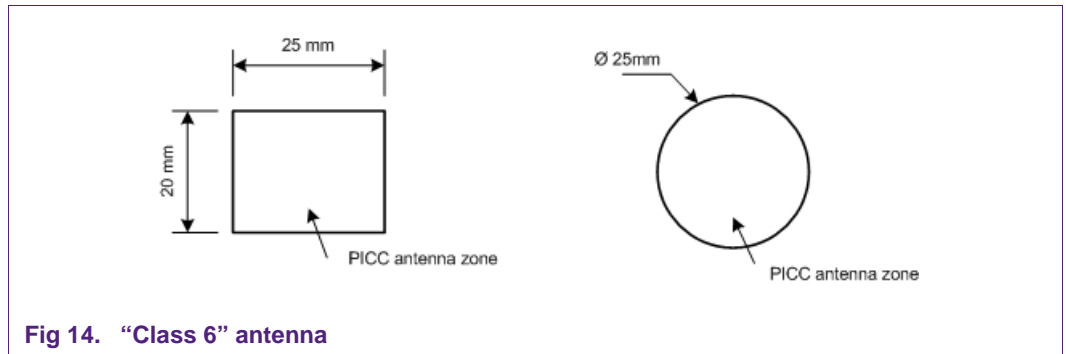

Fig 13. "Class 5" antenna

5.1.4 “Class 6” antenna

The antenna of a “Class 6” design shall be located within a zone defined by either a rectangle of dimensions 25 x 20mm or a circle of 25mm diameter.



5.2 Reference antennas for NFC tags on PCBs

NXP also offers reference designs for the “Class4”, “Class5” and “Class6” antennas as a NFC tag.

5.2.1 “Class 4” reference antenna

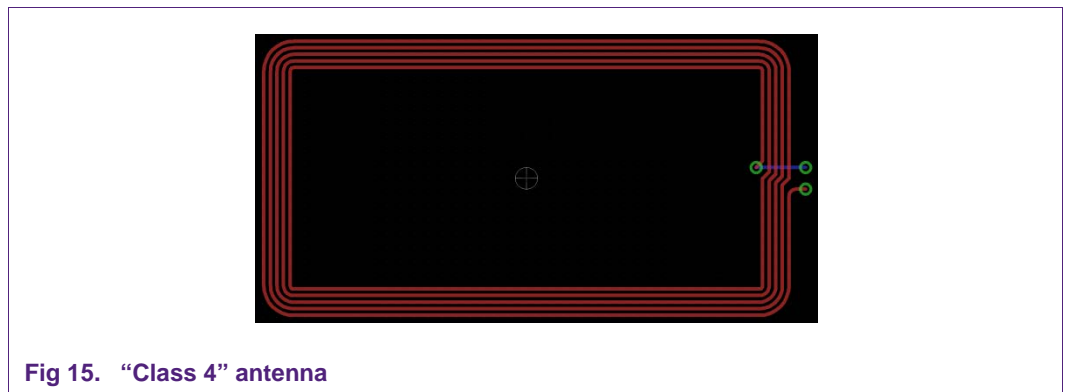

The Gerber file for the reference design: [Class\\_4.zip](#)

5.2.2 “Class 5” reference antenna

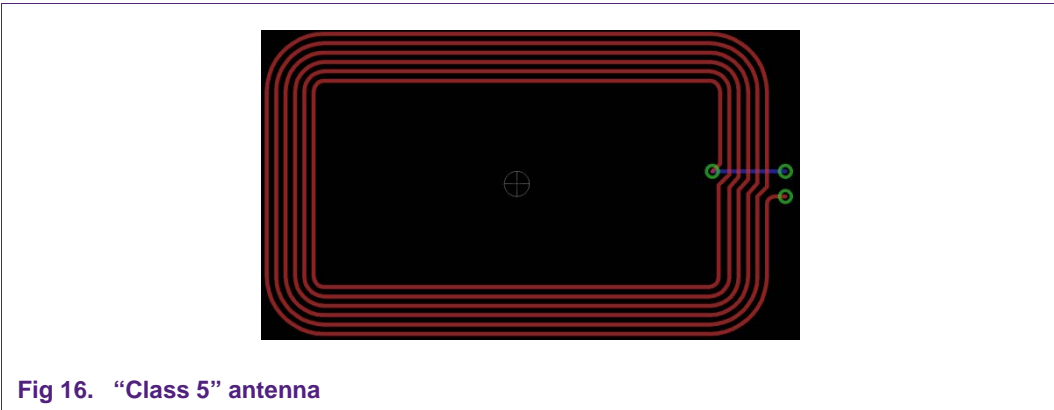

The Gerber file for the reference design: [Class\\_5.zip](#)

5.2.3 “Class 6” reference antenna

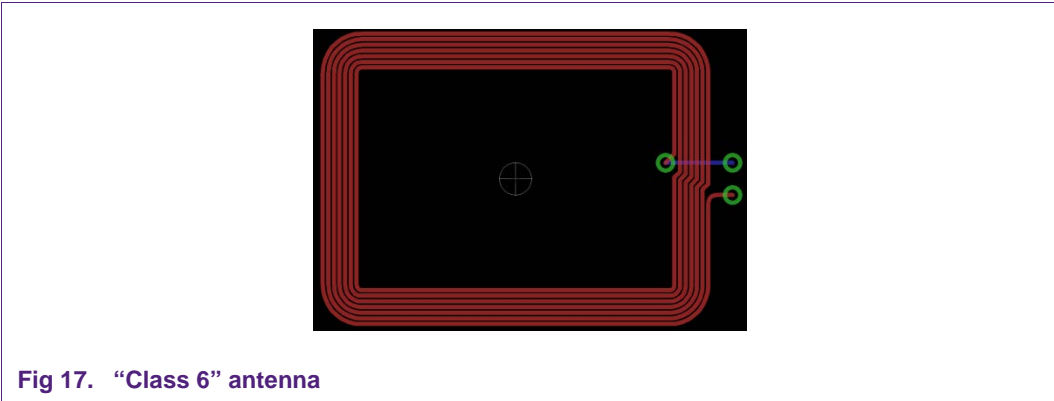

The Gerber file for the reference design: [Class\\_6.zip](#)



### 6.2 NTAG 203F demo and reference board “Class 6” antenna

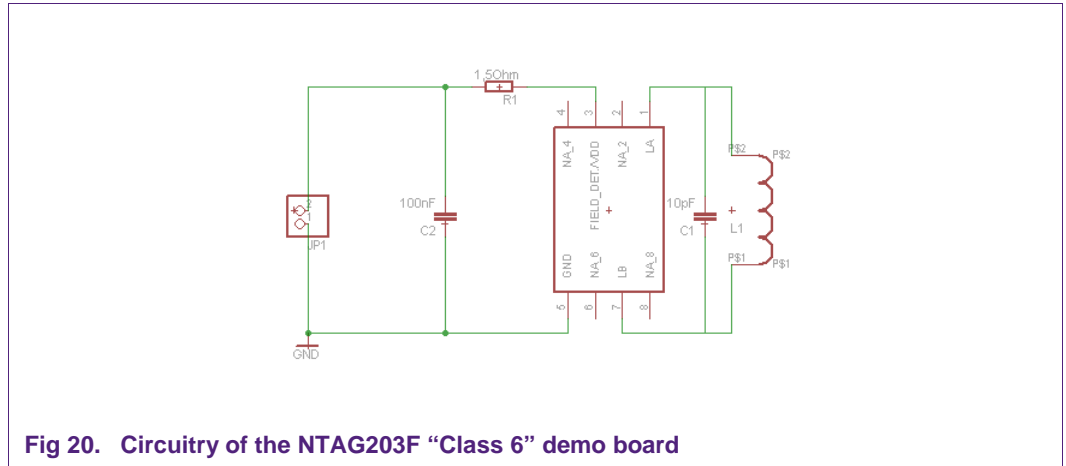

Fig 20. Circuitry of the NTAG203F “Class 6” demo board

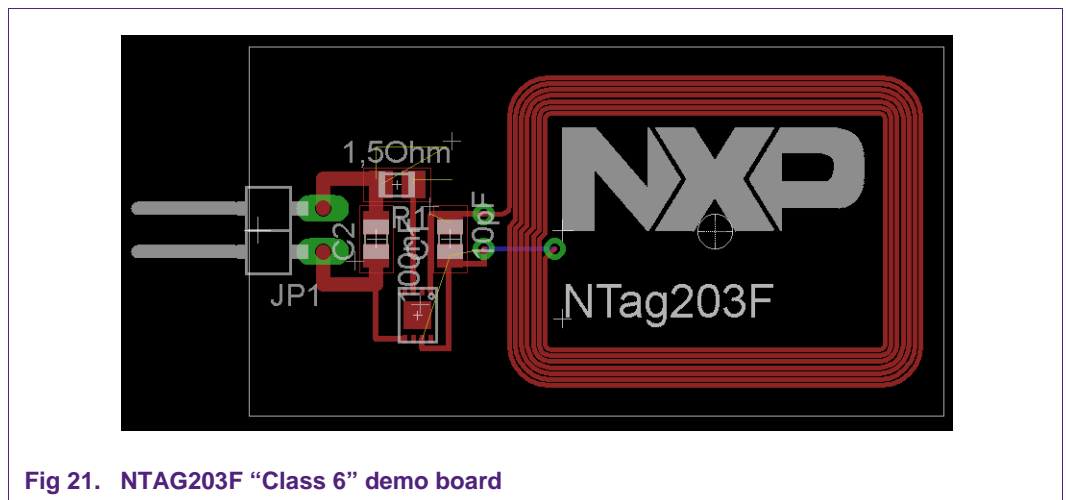

Fig 21. NTAG203F “Class 6” demo board

The Eagle files for the reference design: [Class\\_6-NTAG203F.zip](#)

The “Class 6” antenna is designed with a ferrite foil to use in a metal environment. More detailed information about HF antenna design with ferrite can be found in the document: [“Design of 13.56 MHz Smartcard Stickers with ferrite for payment and Authentication.pdf”](#).

6.3 NTAG I2C plus Explorer board antenna

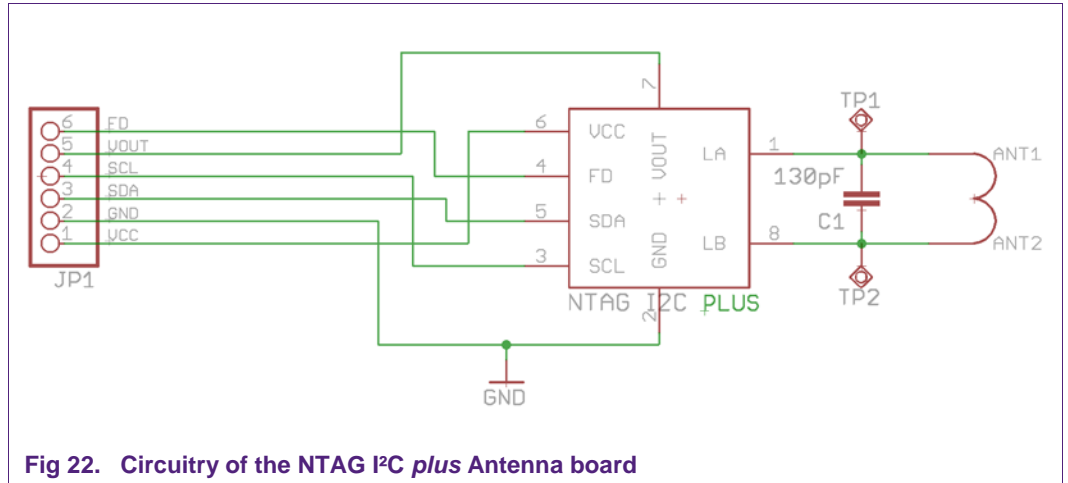

Fig 22. Circuitry of the NTAG I2C plus Antenna board

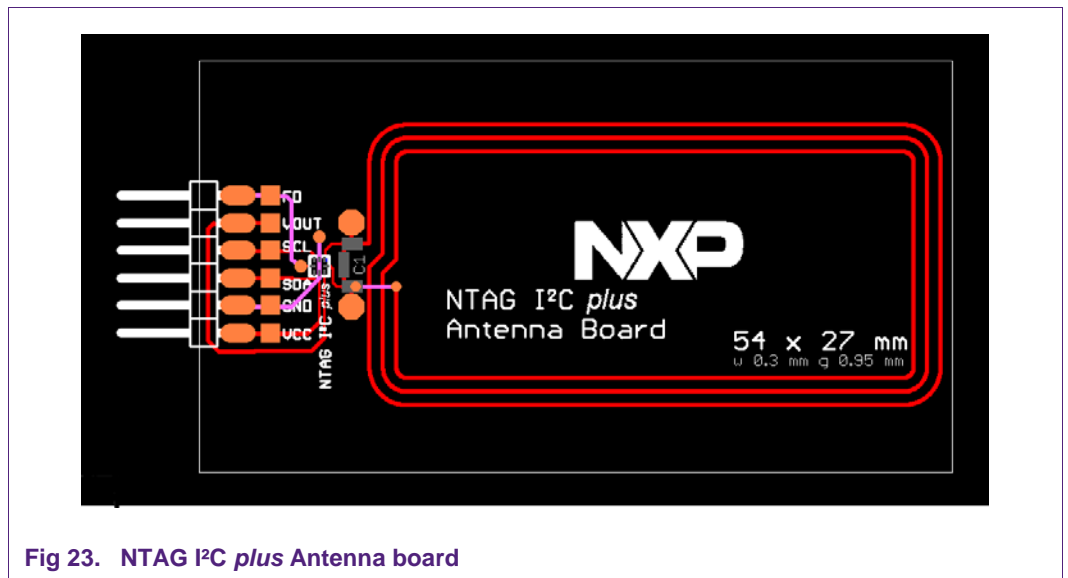

Fig 23. NTAG I2C plus Antenna board

The Eagle files for the reference design:  
<http://www.nxp.com/documents/software/SW3639.zip>

## 7. List of abbreviations

This document uses the following list of abbreviations:

$A_c$	Average antenna area
$A_{Active}$	Active antenna area
$A_i$	Area of antenna winding i
$a_{avg}, b_{avg}$	Average dimensions of the antenna
$a_{max}, b_{max}$	Maximum dimensions of the antenna
$a_o, b_o$	Overall dimensions of the antenna
$C_c$	Antenna capacitance
$C_{br}$	Bridge capacitance
$C_{Con}$	Capacitance due the connection NTAG IC – antenna
$C_{IC}$	NTAG IC input capacitance
$C_{ICT}$	NTAG IC input capacitance for threshold condition
$C_{in}$	Designed inlet capacitance
$C_{it}$	Inter turn capacitance of the antenna
$C_{pl}$	Parallel equivalent capacitance of the inlet
$C_{plT}$	Parallel equivalent capacitance of the inlet for threshold condition
$d$	Antenna wire diameter
$f$	Frequency
$f_{op}$	Operating frequency
$f_R$	Resonance frequency of the inlet
$f_{RT}$	Threshold resonance frequency of the inlet
$g$	Gap between the tracks
$H_T$	Threshold field strength
$H_{Tmin}$	Minimal threshold field strength
$H_{Top}$	Threshold field strength at operating frequency
$I_1$	Reader antenna current
$L_{calc}$	Inductance calculated out of the geometrical antenna parameters
$L_o$	Objective inductance of the antenna
$L_{pc}$	Parallel equivalent inductance of the antenna
$L_{sc}$	Serial equivalent inductance of the antenna

$M$	Mutual inductance between the inlet antenna and reader antenna
$N_c$	Number of turns of the antenna
$p$	Turn exponent
$Q$	Quality factor of the inlet
$Q_{pc}$	Quality factor of the antenna for parallel equivalent circuit
$Q_{sc}$	Quality factor of the antenna for serial equivalent circuit
$Q_T$	Threshold quality factor of the inlet
$R_{Con}$	Resistance of the connection NTAG IC – antenna
$R_{IC}$	NTAG IC input resistance
$R_{ICT}$	NTAG IC input resistance for threshold condition
$R_{pc}$	Parallel equivalent resistance of the antenna
$R_{pl}$	Parallel equivalent resistance of the inlet
$R_{plT}$	Parallel equivalent resistance of the inlet at threshold condition
$R_{sc}$	Serial equivalent resistance of the antenna
$t$	Track thickness
$V_{LA-LB}$	NTAG IC input voltage
$V_{LA-LB \min}$	Minimal voltage level for NTAG IC operation
$w$	Track width

## 8. Reference documentation

NXP provides several documents to support the development of customized antennas.

### 8.1 Datasheets

NXP provides the following datasheets:

- NTAG203F, NFC Forum Type 2 Tag compliant IC with 144 bytes user memory and field detection; [http://www.nxp.com/restricted\\_documents/53420/NTAG203F.pdf](http://www.nxp.com/restricted_documents/53420/NTAG203F.pdf)
- NTAG210\_212, NFC Forum Type 2 Tag compliant IC with 48/128 bytes user memory; [http://www.nxp.com/documents/data\\_sheet/NTAG210\\_212.pdf](http://www.nxp.com/documents/data_sheet/NTAG210_212.pdf)
- NTAG213\_215\_216, NFC Forum Type 2 Tag compliant IC with 144/504/888 bytes user memory  
[http://www.nxp.com/documents/data\\_sheet/NTAG213\\_215\\_216.pdf](http://www.nxp.com/documents/data_sheet/NTAG213_215_216.pdf)
- NTAG213F\_216F, NFC Forum Type 2 Tag compliant IC with 144/888 bytes user memory and field detection  
[http://www.nxp.com/documents/data\\_sheet/NTAG213F\\_216F.pdf](http://www.nxp.com/documents/data_sheet/NTAG213F_216F.pdf)
- NT3H1101/NT3H1201, NTAG I<sup>2</sup>C - Energy harvesting NFC Forum Type 2 Tag with field detection pin and I<sup>2</sup>C interface  
[http://www.nxp.com/documents/data\\_sheet/NT3H1101\\_1201.pdf](http://www.nxp.com/documents/data_sheet/NT3H1101_1201.pdf)
- NT3H2111/NT3H2211, NTAG I<sup>2</sup>C *plus*, NFC Forum Type 2 Tag compliant IC with I<sup>2</sup>C interface [http://www.nxp.com/documents/data\\_sheet/NT3H2111\\_2211.pdf](http://www.nxp.com/documents/data_sheet/NT3H2111_2211.pdf)

### 8.2 Application notes

NXP provides the following application notes:

- AN11141; NTAG203F, How to use the FD pin;  
[http://www.nxp.com/documents/application\\_note/AN11141.pdf](http://www.nxp.com/documents/application_note/AN11141.pdf)
- AN11383, NTAG21x Field Detection and sleep mode feature  
[http://www.nxp.com/documents/application\\_note/AN11383.pdf](http://www.nxp.com/documents/application_note/AN11383.pdf)
- AN11350; NTAG Originality Signature Validation;  
[http://www.nxp.com/documents/application\\_note/AN11350.pdf](http://www.nxp.com/documents/application_note/AN11350.pdf)

### 8.3 ISO/IEC standards

- [1] ISO/IEC 10373-6:2011, *Identification cards — Test methods — Part 6: Proximity cards*
- [2] ISO/IEC 14443-1:2008, *Identification cards — Contactless integrated circuit cards — Proximity cards — Part 1: Physical characteristics*
- [3] ISO/IEC 14443-1:2008/Amd 1:2012, *Additional PICC classes*
- [4] ISO/IEC 14443-2:2010, *Identification cards — Contactless integrated circuit cards — Proximity cards — Part 2: Radio frequency power and signal interface*

- [5] ISO/IEC 14443-2:2010/Amd 2:2012, *Additional PICC classes*
- [6] ISO/IEC 14443-3:2011, *Identification cards — Contactless integrated circuit cards — Proximity cards — Part 3: Initialization and anticollision*
- [7] ISO/IEC 18092:2004, *Information technology — Telecommunications and information exchange between systems — Near Field Communication — Interface and Protocol (NFCIP-1)*
- [8] ISO/IEC 21481:2012, *Information technology — Telecommunications and information exchange between systems — Near Field Communication Interface and Protocol -2 (NFCIP-2)*

## 9. Legal information

### 9.1 Definitions

**Draft** — The document is a draft version only. The content is still under internal review and subject to formal approval, which may result in modifications or additions. NXP Semiconductors does not give any representations or warranties as to the accuracy or completeness of information included herein and shall have no liability for the consequences of use of such information.

### 9.2 Disclaimers

**Limited warranty and liability** — Information in this document is believed to be accurate and reliable. However, NXP Semiconductors does not give any representations or warranties, expressed or implied, as to the accuracy or completeness of such information and shall have no liability for the consequences of use of such information.

In no event shall NXP Semiconductors be liable for any indirect, incidental, punitive, special or consequential damages (including - without limitation - lost profits, lost savings, business interruption, costs related to the removal or replacement of any products or rework charges) whether or not such damages are based on tort (including negligence), warranty, breach of contract or any other legal theory.

Notwithstanding any damages that customer might incur for any reason whatsoever, NXP Semiconductors' aggregate and cumulative liability towards customer for the products described herein shall be limited in accordance with the Terms and conditions of commercial sale of NXP Semiconductors.

**Right to make changes** — NXP Semiconductors reserves the right to make changes to information published in this document, including without limitation specifications and product descriptions, at any time and without notice. This document supersedes and replaces all information supplied prior to the publication hereof.

**Suitability for use** — NXP Semiconductors products are not designed, authorized or warranted to be suitable for use in life support, life-critical or safety-critical systems or equipment, nor in applications where failure or malfunction of an NXP Semiconductors product can reasonably be expected to result in personal injury, death or severe property or environmental damage. NXP Semiconductors accepts no liability for inclusion and/or use of NXP Semiconductors products in such equipment or applications and therefore such inclusion and/or use is at the customer's own risk.

**Applications** — Applications that are described herein for any of these products are for illustrative purposes only. NXP Semiconductors makes no representation or warranty that such applications will be suitable for the specified use without further testing or modification.

Customers are responsible for the design and operation of their applications and products using NXP Semiconductors products, and NXP Semiconductors accepts no liability for any assistance with applications or customer product design. It is customer's sole responsibility to determine

whether the NXP Semiconductors product is suitable and fit for the customer's applications and products planned, as well as for the planned application and use of customer's third party customer(s). Customers should provide appropriate design and operating safeguards to minimize the risks associated with their applications and products.

NXP Semiconductors does not accept any liability related to any default, damage, costs or problem which is based on any weakness or default in the customer's applications or products, or the application or use by customer's third party customer(s). Customer is responsible for doing all necessary testing for the customer's applications and products using NXP Semiconductors products in order to avoid a default of the applications and the products or of the application or use by customer's third party customer(s). NXP does not accept any liability in this respect.

**Export control** — This document as well as the item(s) described herein may be subject to export control regulations. Export might require a prior authorization from competent authorities.

**Evaluation products** — This product is provided on an "as is" and "with all faults" basis for evaluation purposes only. NXP Semiconductors, its affiliates and their suppliers expressly disclaim all warranties, whether express, implied or statutory, including but not limited to the implied warranties of non-infringement, merchantability and fitness for a particular purpose. The entire risk as to the quality, or arising out of the use or performance, of this product remains with customer.

In no event shall NXP Semiconductors, its affiliates or their suppliers be liable to customer for any special, indirect, consequential, punitive or incidental damages (including without limitation damages for loss of business, business interruption, loss of use, loss of data or information, and the like) arising out of the use of or inability to use the product, whether or not based on tort (including negligence), strict liability, breach of contract, breach of warranty or any other theory, even if advised of the possibility of such damages.

Notwithstanding any damages that customer might incur for any reason whatsoever (including without limitation, all damages referenced above and all direct or general damages), the entire liability of NXP Semiconductors, its affiliates and their suppliers and customer's exclusive remedy for all of the foregoing shall be limited to actual damages incurred by customer based on reasonable reliance up to the greater of the amount actually paid by customer for the product or five dollars (US\$5.00). The foregoing limitations, exclusions and disclaimers shall apply to the maximum extent permitted by applicable law, even if any remedy fails of its essential purpose.

### 9.3 Trademarks

Notice: All referenced brands, product names, service names and trademarks are property of their respective owners.

**MIFARE** — is a trademark of NXP B.V.

## 10. List of figures

---

Fig 1.	NTAG IC .....	4
Fig 2.	Equivalent circuit of the NTAG IC .....	4
Fig 3.	Series equivalent circuit of the antenna .....	5
Fig 4.	Parallel equivalent circuit of the antenna .....	6
Fig 5.	Equivalent circuit of the tag .....	7
Fig 6.	Simplified equivalent circuit of the tag .....	7
Fig 7.	Threshold field strength vs. frequency .....	10
Fig 8.	Design flow .....	15
Fig 9.	Rectangular antenna design .....	18
Fig 10.	Round antenna design .....	19
Fig 11.	“Class 3” antenna .....	32
Fig 12.	“Class 4” antenna .....	33
Fig 13.	“Class 5” antenna .....	33
Fig 14.	“Class 6” antenna .....	34
Fig 15.	“Class 4” antenna .....	34
Fig 16.	“Class 5” antenna .....	35
Fig 17.	“Class 6” antenna .....	35
Fig 18.	Circuitry of the NTAG203F “Class 5” demo board .....	36
Fig 19.	NTAG203F “Class 5” demo board .....	36
Fig 20.	Circuitry of the NTAG203F “Class 6” demo board .....	37
Fig 21.	NTAG203F “Class 6” demo board .....	37
Fig 22.	Circuitry of the NTAG I <sup>2</sup> C <i>plus</i> Antenna board .....	38
Fig 23.	NTAG I <sup>2</sup> C <i>plus</i> Antenna board .....	38

## 11. List of tables

---

Table 1.	Capacitance value of NTAG IC .....	5
Table 2.	Antenna inter turn capacitance .....	16
Table 3.	Rectangular antenna parameter .....	18
Table 4.	Round antenna parameters .....	19
Table 5.	Turn exponent $p$ .....	21
Table 6.	Turn exponent $p$ .....	22
Table 7.	First matrix run .....	22
Table 8.	First matrix run .....	23
Table 9.	Result table .....	23
Table 10.	Optimum antenna .....	23
Table 11.	Summary table of parameters of antenna $j$ (rectangular).....	24
Table 12.	Summary table of parameters of antenna $j$ (round) .....	24
Table 13.	Measurement results .....	24
Table 14.	Inductance comparison.....	25
Table 15.	Parameter summary .....	25
Table 16.	Measurement results .....	26
Table 17.	Inductance comparison.....	27
Table 18.	Parameter summary .....	27
Table 19.	Second matrix run.....	29
Table 20.	Result table .....	30
Table 21.	Optimum antenna .....	30
Table 22.	Summary table of parameters of antenna $k$ ....	30

## 12. Contents

<b>1.</b>	<b>Introduction</b> .....	<b>3</b>	4.4.2.4	Estimation of turn exponent $p$ .....	21
1.1	Structure of the document .....	3	4.5	Definition of matrix run.....	22
<b>2.</b>	<b>Antenna theory</b> .....	<b>4</b>	4.5.1	Rectangular (square) antennas .....	22
2.1	NTAG IC connections .....	4	4.5.1.1	Matrix run definition .....	22
2.1.1	NTAG IC equivalent circuit .....	4	4.5.2	Round antennas .....	22
2.1.2	NTAG IC input capacitance $C_{IC}$ .....	4	4.5.2.1	Matrix run definition .....	22
2.2	Series and parallel equivalent circuits .....	5	4.6	Final antenna/ tag.....	23
2.2.1	Series equivalent circuit of the antenna .....	5	4.6.1	Choosing the best antenna.....	23
2.2.2	Parallel equivalent circuit of the antenna.....	6	4.7	Determination of best antenna parameters .....	24
2.2.3	Equivalent circuit of the tag .....	6	4.7.1	Rectangular antennas .....	24
2.3	Resonance frequency and qualification factor of the tag .....	8	4.7.1.1	Equivalent circuit measurement and evaluation of antennas.....	24
2.3.1	Threshold resonance frequency $f_{RT}$ and threshold quality factor $Q_T$ .....	8	4.7.1.2	Calculation of objective antenna inductance $L_{o,i}$ .....	25
2.4	Threshold field strength $H_T$ .....	10	4.7.1.3	Minimal difference between $L_{pc,i}$ and $L_{o,i}$ .....	25
<b>3.</b>	<b>Antenna measurement methods</b> .....	<b>12</b>	4.7.1.4	Determination of turn exponent $p$ .....	26
3.1	Antenna characterization .....	12	4.7.2	Round antennas .....	26
3.1.1	Impedance analyzer with equivalent circuit calculation .....	12	4.7.2.1	Equivalent circuit measurement and evaluation of antennas.....	26
3.1.2	Method for ISO/IEC 7810 ID-1 sized card.....	12	4.7.2.2	Calculation of the objective antenna inductance $L_{o,i}$ .....	26
3.1.3	Impedance analyzer or LCR meter .....	13	4.7.2.3	Minimal difference between $L_{pc,i}$ and $L_{o,i}$ .....	27
3.1.4	Reference measurement using capacitor.....	14	4.7.2.4	Determination of turn exponent $p$ .....	27
3.1.5	Minimum field strength measurement .....	14	4.8	Second matrix run definition .....	29
<b>4.</b>	<b>Antenna design procedure</b> .....	<b>15</b>	4.8.1	Rectangular antennas .....	29
4.1	Design flow.....	15	4.8.2	Circular antennas .....	29
4.2	Estimation of electrical parameters .....	16	4.8.3	Table for optimized antennas .....	29
4.2.1	Ideal threshold frequency $f_{IDEAL}$ determination .	16	4.9	Determining optimized antenna from second matrix run .....	30
4.2.2	Estimation of the antenna capacitance $C_c$ .....	16	4.9.1	Tag with IC .....	30
4.2.3	Estimation of the connection capacitance $C_{Con}$	16	4.9.2	Choosing the best antenna.....	30
4.2.4	Calculation of objective antenna inductance $L_o$ based on an estimated tag capacitance $C_{pIT}$ ....	17	4.10	Antenna calculation tools.....	31
4.3	Determination of objective inductance $L_o$ .....	17	<b>5.</b>	<b>Antenna classes</b> .....	<b>32</b>
4.3.1	Rectangular (square) antennas.....	17	5.1	Class definition .....	32
4.3.1.1	Calculation of inductance .....	17	5.1.1	“Class 3” antenna .....	32
4.3.2	Round antennas.....	19	5.1.2	“Class 4” antenna .....	32
4.4	Determination of dimensional limits.....	20	5.1.3	“Class 5” antenna .....	33
4.4.1	Rectangular (square) antennas.....	20	5.1.4	“Class 6” antenna .....	34
4.4.1.1	Maximum antenna dimensions $a_{max}$ , $b_{max}$ .....	20	5.2	Reference antennas for NFC tags on PCBs.....	34
4.4.1.2	Gap between the tracks $g$ .....	20	5.2.1	“Class 4” reference antenna .....	34
4.4.1.3	Track thickness $t$ and track width $w$ .....	20	5.2.2	“Class 5” reference antenna .....	35
4.4.1.4	Estimation of turn exponent $p$ .....	20	5.2.3	“Class 6” reference antenna .....	35
4.4.2	Round antennas.....	21	<b>6.</b>	<b>NTAG demo boards and reference designs</b> .....	<b>36</b>
4.4.2.1	Maximum antenna dimension $D_{max}$ .....	21	6.1	NTAG 203F demo and reference board “Class 5” antenna .....	36
4.4.2.2	Gap between tracks $g$ .....	21			
4.4.2.3	Track thickness $t$ and track width $w$ .....	21			

6.2 NTAG 203F demo and reference board “Class 6” antenna ..... 37

6.3 NTAG I<sup>2</sup>C *plus* Explorer board antenna ..... 38

**7. List of abbreviations ..... 39**

**8. Reference documentation ..... 41**

8.1 Datasheets ..... 41

8.2 Application notes ..... 41

8.3 ISO/IEC standards ..... 41

**9. Legal information ..... 43**

9.1 Definitions ..... 43

9.2 Disclaimers ..... 43

9.3 Trademarks ..... 43

**10. List of figures ..... 44**

**11. List of tables ..... 45**

**12. Contents ..... 46**

---

Please be aware that important notices concerning this document and the product(s) described herein, have been included in the section 'Legal information'.

---

© NXP B.V. 2016.

All rights reserved.

For more information, visit: <http://www.nxp.com>

For sales office addresses, please send an email to: [salesaddresses@nxp.com](mailto:salesaddresses@nxp.com)

Date of release: 27 April 2016  
242115

Document identifier: AN11276