

Evaluating the ADA4510-2 Precision, 40 V, ± 70 nV/ $^{\circ}$ C, Rail-to-Rail Input and Output Op Amp with DigiTrim

FEATURES

- ▶ Full featured evaluation board for the [ADA4510-2](#), a dual-channel, low input bias current amplifier available in an 8-lead narrow-body SOIC
- ▶ Enables quick prototyping
- ▶ User defined circuit configuration
- ▶ Edge mounted SMA connectors
- ▶ Connects easily to test equipment and other circuits
- ▶ Available provisions for photodiode sensors for quick evaluation
 - ▶ Connections available for photodiode bias
 - ▶ Guard traces to minimize leakage

GENERAL DESCRIPTION

The EVAL-ADA4510-2ARZ is an evaluation board used to test the ADA4510-2, a dual-channel, low input bias current amplifier that comes in an 8-lead, standard small outline package (SOIC_N). The design of this evaluation board emphasizes simplicity and ease of use. Provisions are available on the board to interface easily to test equipment.

The EVAL-ADA4510-2ARZ uses surface-mount components (SMT) in case size 0603, except for bypass capacitors and termination resistors. The EVAL-ADA4510-2ARZ features a variety of unpopulated resistor and capacitor footprints that provide the user with multiple choices and extensive flexibility for different application circuits.

The evaluation board has provisions for photodiode sensors that allow for easy configuration of a transimpedance amplifier (TIA). The layout is optimized with provisions for guarding to ensure low leakage and low parasitic capacitance for TIA applications.

Additionally, the evaluation board has provisions to build different types of filters. For selecting specific component values and designing filters, refer to <https://tools.analog.com/en/filterwizard/>.

Full details about the part are available in the ADA4510-2 data sheet, which must be consulted when using the EVAL-ADA4510-2ARZ.

EVALUATION BOARD PHOTOGRAPH

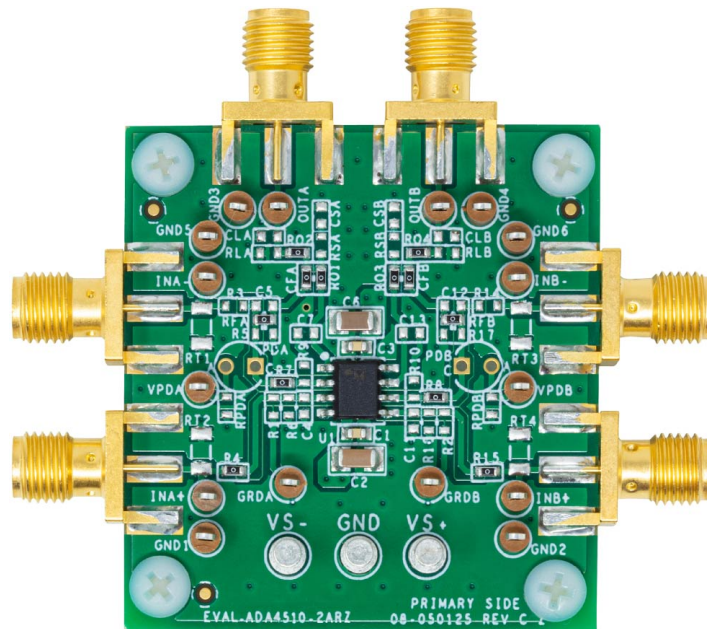

Figure 1. EVAL-ADA4510-2ARZ Evaluation Board Photograph

TABLE OF CONTENTS

Features.....	1	Transimpedance Amplifier (TIA)	
General Description.....	1	Configuration.....	3
Evaluation Board Photograph.....	1	Configuration Table.....	3
Evaluation Board Quick Start Operation.....	3	Board Configuration.....	4
Overview.....	3	Evaluation Board Schematics and Artwork.....	5
Power Supply.....	3	Ordering Information.....	7
Amplifier Configuration.....	3	Bill of Materials.....	7
Power-Up Procedure.....	3		

REVISION HISTORY**7/2023—Revision 0: Initial Version**

EVALUATION BOARD QUICK START OPERATION

OVERVIEW

This section outlines the basic configuration of the EVAL-ADA4510-2ARZ board to test basic functionality of the device. Provisions are included on the board so that it is highly configurable for any application. The connectors available on the board provide an easy interface to various bench equipment.

POWER SUPPLY

The EVAL-ADA4510-2ARZ uses turret connectors for the power supply connections. The board comes installed with 0.1 μF and 10 μF decoupling capacitors on both supplies. Apply the positive supply to the VS+ connector and the negative supply to the VS- connector.

AMPLIFIER CONFIGURATION

Both channels on the EVAL-ADA4510-2ARZ board are configured in a noninverting configuration with a gain of +1 by default. Pre-installed resistors accommodate this configuration. Figure 2 shows the default connections on the board.

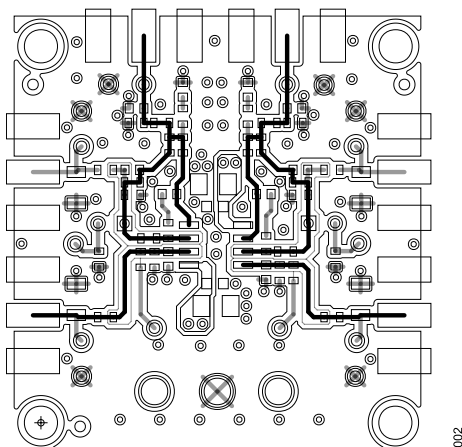

Figure 2. Default Connection

POWER-UP PROCEDURE

To begin using the EVAL-ADA4510-2ARZ board, use the following procedure:

1. Connect the power supply wires to the VS+, VS-, and GND turrets, respectively.
2. Connect an oscilloscope to the OUTA and OUTB Subminiature Version A (SMA) connectors.
3. Connect an input signal source to INA+ and INB+.
4. Set the signal source to the preferred amplitude and frequency while keeping the peak-to-peak input signal within the input voltage range of the device to ensure proper operation.
5. Set the power supplies to 18 V and -18 V.
6. Turn on the power supplies.
7. Turn on the input signal source.

The oscilloscope reads the same amplitude and frequency as the input signal.

TRANSIMPEDANCE AMPLIFIER (TIA) CONFIGURATION

The low input bias current and low input capacitance of the ADA4510-2 amplifier makes the op amp a good choice for transimpedance configurations as shown in Figure 4 and Figure 5. The evaluation board has an on-board provision for a photodiode (radial package) on both channels of the amplifier and is fabricated with a guard trace around the inverting pins (-INA, -INB) to ensure minimal leakage when evaluating in a transimpedance configuration. The R1 connection for Channel A and the R2 connection for Channel B provide quick connections of the guard trace to the noninverting pins (+INA, +INB) of the amplifier.

When operating in a TIA configuration, a bias voltage can be applied to the VPDA pin or to the VPDB pin to bias the anode of the photodiode. If no bias voltage needs to be applied, install a 0 Ω resistor at the RPDA footprint or the RPDB footprint to connect the anode of the photodiode to ground. For this TIA configuration, install the photodiode at either the PDA footprint or the PDB footprint and connect a feedback resistor at the RFA footprint for Channel A or the RFB footprint for Channel B. A feedback capacitor at the C5 footprint or the C12 footprint can be added for stability of the circuit.

CONFIGURATION TABLE

Table 1. Configuration Table

Component	Description
R3, R14	INA- or INB- can be used by installing a resistor on the R3 slot or the R14 slot
R4, R15	INA+ or INB+ can be used by installing a resistor on the R4 or the R15 slot
RT1, RT2, RT3, RT4	Termination resistors
RSA, CSA and RSB, CSB	Snubber circuit
RLA, RLB	Load resistor
CLA, CLB	Load capacitor
PDA, PDB	Photodiode slot
RPDA, RPDB	Set the PDA slot and the PDB slot to photovoltaic mode

EVALUATION BOARD QUICK START OPERATION

BOARD CONFIGURATION

Figure 3 shows the locations of board components described in Table 1.

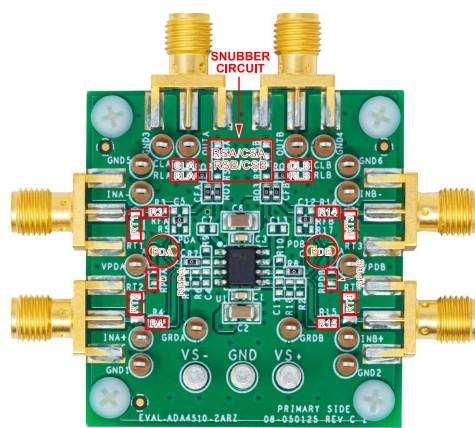

Figure 3. Board Configuration

EVALUATION BOARD SCHEMATICS AND ARTWORK

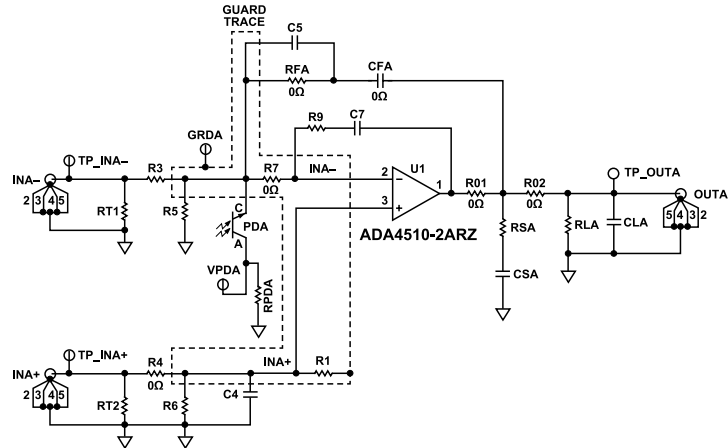

Figure 4. Channel A Circuit Connections

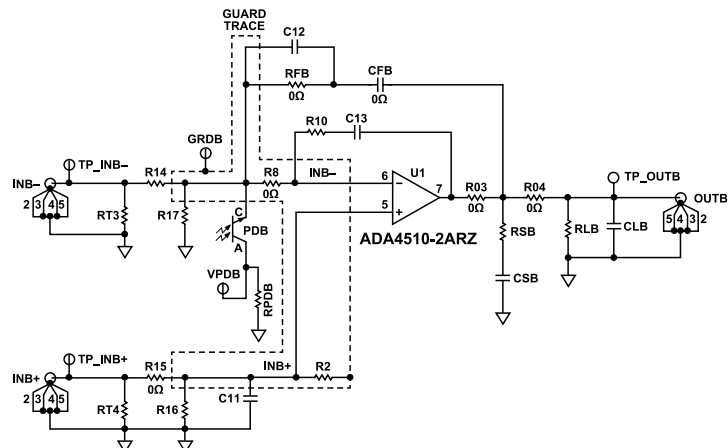

Figure 5. Channel B Circuit Connections

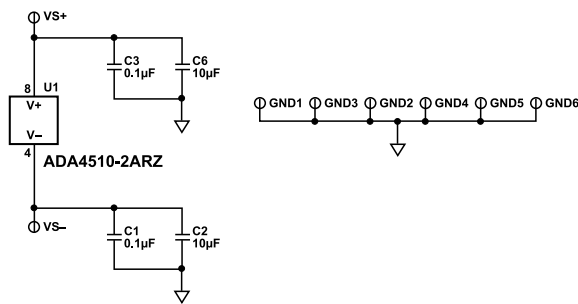
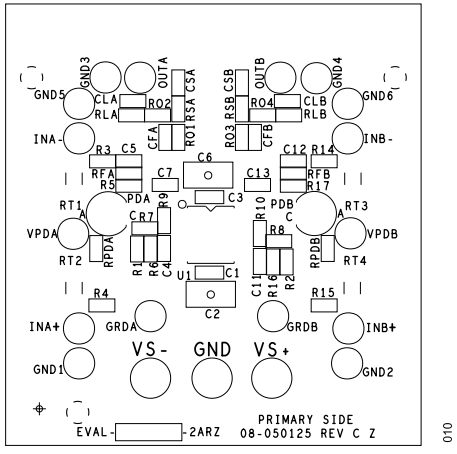

Figure 6. Power and Ground Connections

EVALUATION BOARD SCHEMATICS AND ARTWORK



010

Figure 7. Assembly Drawing, Primary Side

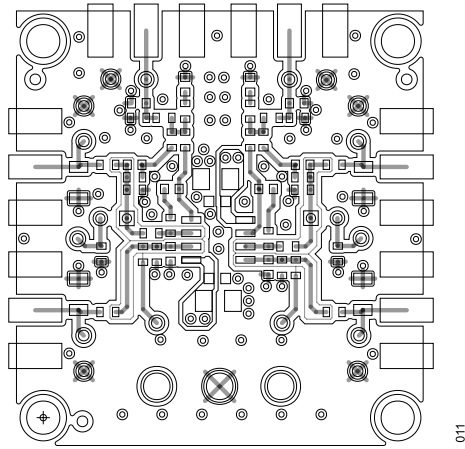

011

Figure 8. Layout Pattern, Primary Side

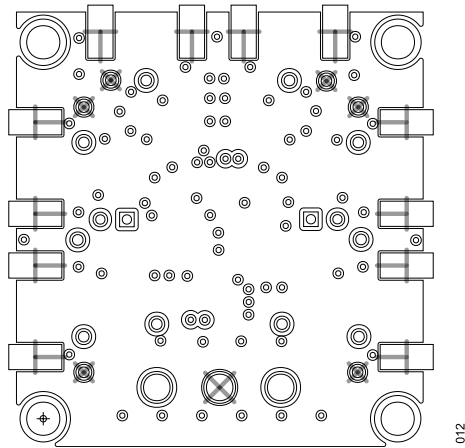

012

Figure 9. Layout Pattern, Secondary Side

ORDERING INFORMATION

BILL OF MATERIALS

Table 2.

Quantity	Reference Designator	Description	Supplier	Part Number
1	U1	8-lead SOIC	Analog Devices, Inc.	ADA4510-2
2	C1, C3	Ceramic capacitors, X7R, 0603, 0.1 μ F, 50 V	Vishay	VJ0603Y104KXAAC31X
2	C2, C6	Ceramic capacitors, X5R, 0603, 10 μ F, 50 V	TDK	C3216X5R1H106K160AB
10	C4, C5, C7, C11, C12, C13, CLA, CLB, CSA, CSB	User defined capacitors, 0603	Not applicable	Not applicable
12	CFA, CFB, R4, R7, R8, R15, RFA, RFB, RO1, RO2, RO3, RO4	0 Ω resistors, 0603	Panasonic	ERJ-3GEY0R00V
16	R1, R2, RPDA, RPDB, R3, R5, R6, R9, R10, R14, R16, R17, RLA, RLB, RSA, RSB	User defined resistors, 0603	Not applicable	Not applicable
4	RT1, RT2, RT3, RT4	User defined resistors, 1206	Not applicable	Not applicable
3	GND, VS+, VS-	Connectors, solder terminal turrets	Mill-Max	2501-2-00-80-00-00-07-0
2	GND1, GND2	Test points, black	Components Corporation	TP-104-01-00
2	PDA, PDB	User defined photodiodes	Not applicable	Not applicable
6	INA+, INA-, INB+, INB-, OUTA, OUTB	Coaxial SMA end launches	Cinch Connectivity Solutions	142-0701-801
16	GND1, GND2, GND3, GND4, GND5, GND6, GRDA, GRDB, TP_INA+, TP_INA-, TP_INB+, TP_INB-, TP_OUTA, TP_OUTB, VPDA, VPDB	Connectors, PCB test points	Keystone Electronics	5115

**ESD Caution**

ESD (electrostatic discharge) sensitive device. Charged devices and circuit boards can discharge without detection. Although this product features patented or proprietary protection circuitry, damage may occur on devices subjected to high energy ESD. Therefore, proper ESD precautions should be taken to avoid performance degradation or loss of functionality.

Legal Terms and Conditions

By using the evaluation board discussed herein (together with any tools, components documentation or support materials, the "Evaluation Board"), you are agreeing to be bound by the terms and conditions set forth below ("Agreement") unless you have purchased the Evaluation Board, in which case the Analog Devices Standard Terms and Conditions of Sale shall govern. Do not use the Evaluation Board until you have read and agreed to the Agreement. Your use of the Evaluation Board shall signify your acceptance of the Agreement. This Agreement is made by and between you ("Customer") and Analog Devices, Inc. ("ADI"), with its principal place of business at Subject to the terms and conditions of the Agreement, ADI hereby grants to Customer a free, limited, personal, temporary, non-exclusive, non-sublicensable, non-transferable license to use the Evaluation Board FOR EVALUATION PURPOSES ONLY. Customer understands and agrees that the Evaluation Board is provided for the sole and exclusive purpose referenced above, and agrees not to use the Evaluation Board for any other purpose. Furthermore, the license granted is expressly made subject to the following additional limitations: Customer shall not (i) rent, lease, display, sell, transfer, assign, sublicense, or distribute the Evaluation Board; and (ii) permit any Third Party to access the Evaluation Board. As used herein, the term "Third Party" includes any entity other than ADI, Customer, their employees, affiliates and in-house consultants. The Evaluation Board is NOT sold to Customer; all rights not expressly granted herein, including ownership of the Evaluation Board, are reserved by ADI. CONFIDENTIALITY. This Agreement and the Evaluation Board shall all be considered the confidential and proprietary information of ADI. Customer may not disclose or transfer any portion of the Evaluation Board to any other party for any reason. Upon discontinuation of use of the Evaluation Board or termination of this Agreement, Customer agrees to promptly return the Evaluation Board to ADI. ADDITIONAL RESTRICTIONS. Customer may not disassemble, decompile or reverse engineer chips on the Evaluation Board. Customer shall inform ADI of any occurred damages or any modifications or alterations it makes to the Evaluation Board, including but not limited to soldering or any other activity that affects the material content of the Evaluation Board. Modifications to the Evaluation Board must comply with applicable law, including but not limited to the RoHS Directive. TERMINATION. ADI may terminate this Agreement at any time upon giving written notice to Customer. Customer agrees to return to ADI the Evaluation Board at that time. LIMITATION OF LIABILITY. THE EVALUATION BOARD PROVIDED HEREUNDER IS PROVIDED "AS IS" AND ADI MAKES NO WARRANTIES OR REPRESENTATIONS OF ANY KIND WITH RESPECT TO IT. ADI SPECIFICALLY DISCLAIMS ANY REPRESENTATIONS, ENDORSEMENTS, GUARANTEES, OR WARRANTIES, EXPRESS OR IMPLIED, RELATED TO THE EVALUATION BOARD INCLUDING, BUT NOT LIMITED TO, THE IMPLIED WARRANTY OF MERCHANTABILITY, TITLE, FITNESS FOR A PARTICULAR PURPOSE OR NON-INFRINGEMENT OF INTELLECTUAL PROPERTY RIGHTS. IN NO EVENT WILL ADI AND ITS LICENSORS BE LIABLE FOR ANY INCIDENTAL, SPECIAL, INDIRECT, OR CONSEQUENTIAL DAMAGES RESULTING FROM CUSTOMER'S POSSESSION OR USE OF THE EVALUATION BOARD, INCLUDING BUT NOT LIMITED TO LOST PROFITS, DELAY COSTS, LABOR COSTS OR LOSS OF GOODWILL. ADI'S TOTAL LIABILITY FROM ANY AND ALL CAUSES SHALL BE LIMITED TO THE AMOUNT OF ONE HUNDRED US DOLLARS (\$100.00). EXPORT. Customer agrees that it will not directly or indirectly export the Evaluation Board to another country, and that it will comply with all applicable United States federal laws and regulations relating to exports. GOVERNING LAW. This Agreement shall be governed by and construed in accordance with the substantive laws of the Commonwealth of Massachusetts (excluding conflict of law rules). Any legal action regarding this Agreement will be heard in the state or federal courts having jurisdiction in Suffolk County, Massachusetts, and Customer hereby submits to the personal jurisdiction and venue of such courts. The United Nations Convention on Contracts for the International Sale of Goods shall not apply to this Agreement and is expressly disclaimed.

