

APPLICATION NOTE

Depletion Mode pHEMT Bias Networks

Introduction

Skyworks provides standalone GaAs pHEMTs that require external bias and RF matching networks to realize their best performance. Parameters such as gain, Noise Figure (NF), and linearity are controlled by the pHEMT's bias point. This Application Note describes the many ways to properly bias a pHEMT and outlines the performance characteristics for each circuit.

pHEMT Bias Conditions

Both the gate and drain of a pHEMT must meet bias conditions to function properly. The drain voltage relative to the source (V_{DS}) should be ≥ 2 V, while the gate voltage relative to the source (V_{GS}) is used to set the current flow from the drain to the source (I_{DD}). Figure 1 shows the basic circuit representation of a pHEMT.

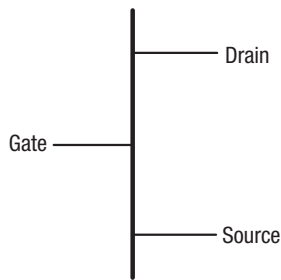

Figure 1. Basic pHEMT Circuit Representation

With $V_{GS} = 0$ V and $V_{DS} \geq 2$ V, the FET is in its saturated state (I_{DSS}) and draws the maximum amount of current. The value of I_{DSS} is determined by the overall geometry and size of the pHEMT. Lowering V_{GS} to approximately -0.7 V, the device enters its pinchoff state and turns off. Typical IV characteristics of a Skyworks 200 μ m FET is illustrated in Figure 2.

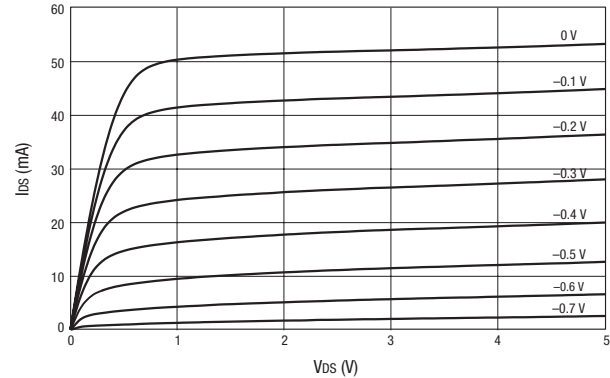

Figure 2. Typical IV Characteristics for a 200 μ m pHEMT

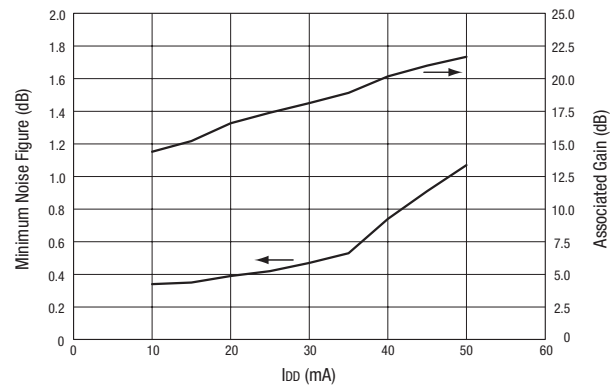

Figure 3. Minimum NF and Associated Gain vs I_{DD} for a 200 μ m pHEMT

Performance Considerations

The bias point chosen for a pHEMT largely controls the performance parameters such as NF, gain, and linearity. Figure 3 illustrates how noise and gain are affected by the I_{DD} . For applications in which noise is the most important specification, the pHEMT should be biased around 20 percent of the I_{DSS} value or, in this case, 10 mA. Increasing I_{DD} increases gain and linearity, but at the expense of an increased NF.

A 200 μ m pHEMT such as the SKY65050-372LF is ideal for low power and low noise applications in which linearity is not a critical specification. If the NF and linearity are both important, a larger device such as the SKY65053-377LF should be considered. This 400 μ m device has an I_{DSS} of 100 mA, which allows it to be biased at a higher I_{DD} point and still maintain a low NF performance.

Bias Circuits

The bias networks shown in Figures 4 and 5 illustrate the two most common ways to bias pHEMTs. Circuit A uses a positive drain voltage (V_D) and a negative gate voltage (V_G) to set the quiescent point of the device. This circuit provides low noise, high gain, and high efficiency. The circuit offers the best performance, but requires a negative voltage supply, which can increase overall component cost and layout area.

To eliminate the need for a negative voltage supply, a self-biasing resistor is placed between the source of the device and ground. The source is floated above ground when current flows through the resistor. The source resistor simplifies the bias network design, but also has a few caveats. The resistor slightly degrades NF performance and the added source bypass capacitor can cause oscillations. The characteristics of both circuits are summarized in Table 1.

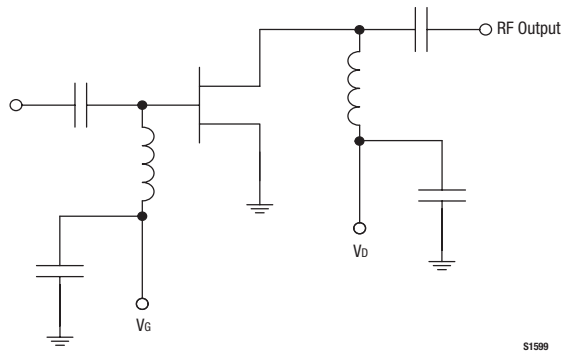

Figure 4. pHEMT Circuit A: Gate and Drain Biased Separately

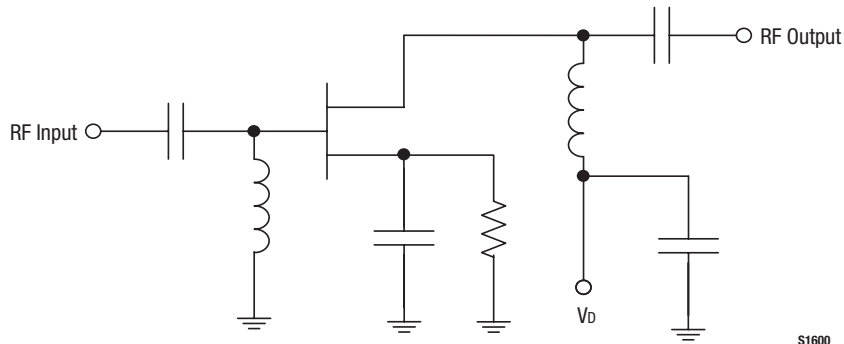

Figure 5. pHEMT Circuit B: Single DC Supply Operation

Table 1. pHEMT Circuit Summary

Circuit (See Figures 4 and 5)	Circuit Characteristics	Power Supply
A	Low noise High gain High efficiency	Positive and negative supply
B	Low noise High gain Lower efficiency Gain and current are adjusted with external resistor	Positive supply

Copyright © 2009 Skyworks Solutions, Inc. All Rights Reserved.

Information in this document is provided in connection with Skyworks Solutions, Inc. ("Skyworks") products or services. These materials, including the information contained herein, are provided by Skyworks as a service to its customers and may be used for informational purposes only by the customer. Skyworks assumes no responsibility for errors or omissions in these materials or the information contained herein. Skyworks may change its documentation, products, services, specifications or product descriptions at any time, without notice. Skyworks makes no commitment to update the materials or information and shall have no responsibility whatsoever for conflicts, incompatibilities, or other difficulties arising from any future changes.

No license, whether express, implied, by estoppel or otherwise, is granted to any intellectual property rights by this document. Skyworks assumes no liability for any materials, products or information provided hereunder, including the sale, distribution, reproduction or use of Skyworks products, information or materials, except as may be provided in Skyworks Terms and Conditions of Sale.

THE MATERIALS, PRODUCTS AND INFORMATION ARE PROVIDED "AS IS" WITHOUT WARRANTY OF ANY KIND, WHETHER EXPRESS, IMPLIED, STATUTORY, OR OTHERWISE, INCLUDING FITNESS FOR A PARTICULAR PURPOSE OR USE, MERCHANTABILITY, PERFORMANCE, QUALITY OR NON-INFRINGEMENT OF ANY INTELLECTUAL PROPERTY RIGHT; ALL SUCH WARRANTIES ARE HEREBY EXPRESSLY DISCLAIMED. SKYWORKS DOES NOT WARRANT THE ACCURACY OR COMPLETENESS OF THE INFORMATION, TEXT, GRAPHICS OR OTHER ITEMS CONTAINED WITHIN THESE MATERIALS. SKYWORKS SHALL NOT BE LIABLE FOR ANY DAMAGES, INCLUDING BUT NOT LIMITED TO ANY SPECIAL, INDIRECT, INCIDENTAL, STATUTORY, OR CONSEQUENTIAL DAMAGES, INCLUDING WITHOUT LIMITATION, LOST REVENUES OR LOST PROFITS THAT MAY RESULT FROM THE USE OF THE MATERIALS OR INFORMATION, WHETHER OR NOT THE RECIPIENT OF MATERIALS HAS BEEN ADVISED OF THE POSSIBILITY OF SUCH DAMAGE.

Skyworks products are not intended for use in medical, lifesaving or life-sustaining applications, or other equipment in which the failure of the Skyworks products could lead to personal injury, death, physical or environmental damage. Skyworks customers using or selling Skyworks products for use in such applications do so at their own risk and agree to fully indemnify Skyworks for any damages resulting from such improper use or sale.

Customers are responsible for their products and applications using Skyworks products, which may deviate from published specifications as a result of design defects, errors, or operation of products outside of published parameters or design specifications. Customers should include design and operating safeguards to minimize these and other risks. Skyworks assumes no liability for applications assistance, customer product design, or damage to any equipment resulting from the use of Skyworks products outside of stated published specifications or parameters.

Skyworks, the Skyworks symbol, and "Breakthrough Simplicity" are trademarks or registered trademarks of Skyworks Solutions, Inc., in the United States and other countries. Third-party brands and names are for identification purposes only, and are the property of their respective owners. Additional information, including relevant terms and conditions, posted at www.skyworksinc.com, are incorporated by reference.